

Assembly & Operation Instructions Model 100

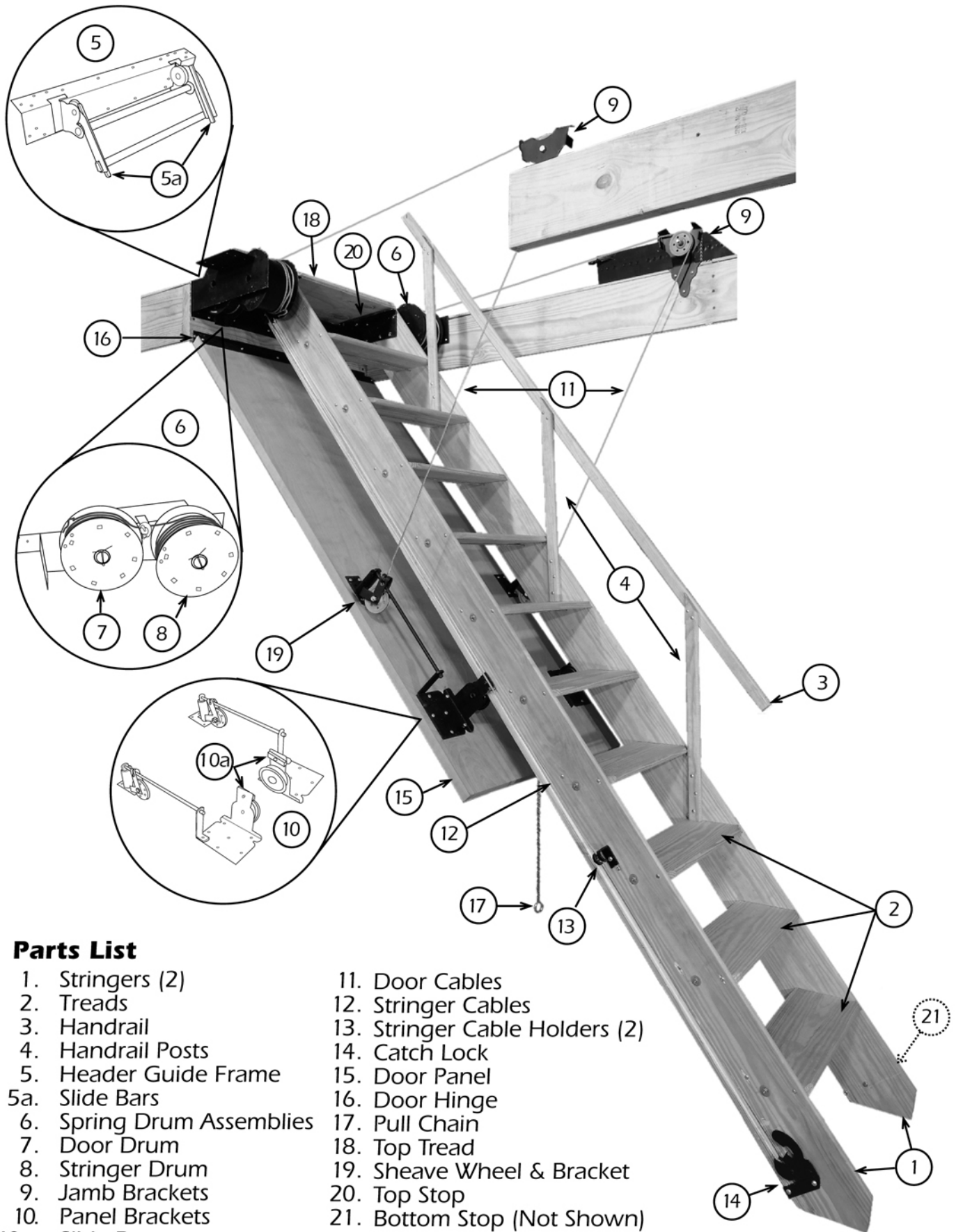

BESSLER
STAIRWAY
COMPANY

Bessler Assembly & Operation Instructions For Model 100



Parts List

- | | |
|---------------------------|--------------------------------|
| 1. Stringers (2) | 11. Door Cables |
| 2. Treads | 12. Stringer Cables |
| 3. Handrail | 13. Stringer Cable Holders (2) |
| 4. Handrail Posts | 14. Catch Lock |
| 5. Header Guide Frame | 15. Door Panel |
| 5a. Slide Bars | 16. Door Hinge |
| 6. Spring Drum Assemblies | 17. Pull Chain |
| 7. Door Drum | 18. Top Tread |
| 8. Stringer Drum | 19. Sheave Wheel & Bracket |
| 9. Jamb Brackets | 20. Top Stop |
| 10. Panel Brackets | 21. Bottom Stop (Not Shown) |
| 10a. Slide Bars | |

Identification Of Fasteners

Model 100 Sizes 1 through 4 use:

Pull Chain Components

- (1) 24" pull chain,
- (1) 3/16" x 2" eye bolt w/nut
- (1) pull ring
- (2) ladder washers
- (12) 10-24 hex nuts
- (24) ladder washers
- (48) #10 x 1-1/4" P.H. screws
- (2) 1/4-20 x 1-1/4" R.H. machine screws w/nuts
- (4) 1/4-20 x 1-1/4" flat head screws w/keps nuts
- (15) #10 x 1-1/4" P.H. Screws
- (53) #10 x 1" P.H. Screws

Model 100 Sizes 5 through 11 use:

Pull Chain Components

- (1) 60" pull chain,
- (1) 3/16" x 2" eye bolt w/nut
- (1) pull ring
- (2) ladder washers
- (16) 10-24 hex nuts
- (32) ladder washers
- (2) 1/4-20 x 1-1/4" R.H. machine screws w/nuts
- (4) 1/4-20 x 1-1/4" flat head screws w/keps nuts
- (20) #10 x 1-1/4" P.H. Screws
- (53) #10 x 1" P.H. Screws
- (64) #10 x 1-1/4" P.H. screws

Check all parts against the Parts List on Page 2.

NOTE: FINISHED JAMB OR CLOSING JAMB AND DOOR STOPS ARE NOT PROVIDED BY BESSLER.



#10 x 1" P.H. Screws



#10 x 1-1/4" P.H. Screws

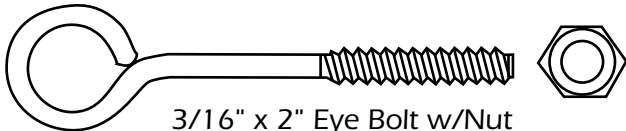

3/16" x 2" Eye Bolt w/Nut

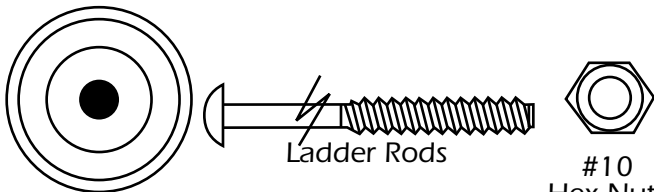

1" Ladder Washers

#10 Hex Nuts



1/4" X 1-1/4" R.H. Machine Screw w/Lock Nut



1/4" X 1-1/4" R.H. Flat Head Screw w/Keeps Nut

Machine Screw w/Lock Nut Flat Head Screw w/Keeps Nut

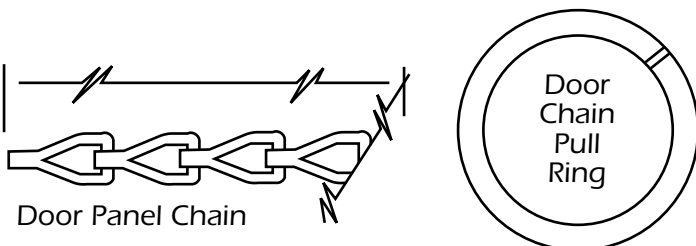

Door Panel Chain

Door Chain Pull Ring

Before You Install.

To make sure you receive the best performance from your Bessler, please take a few moments to familiarize yourself with all of the parts and guidelines. Seek professional help if not experienced in carpentry. Example: An experienced finish carpenter with good help should easily install the door jamb and stairs and adjust for operation in four hours or less. Time is directly dependent on skill and the understanding of these instructions. This is a stairway; take your time, work safe and eliminate liabilities.

Figure 1

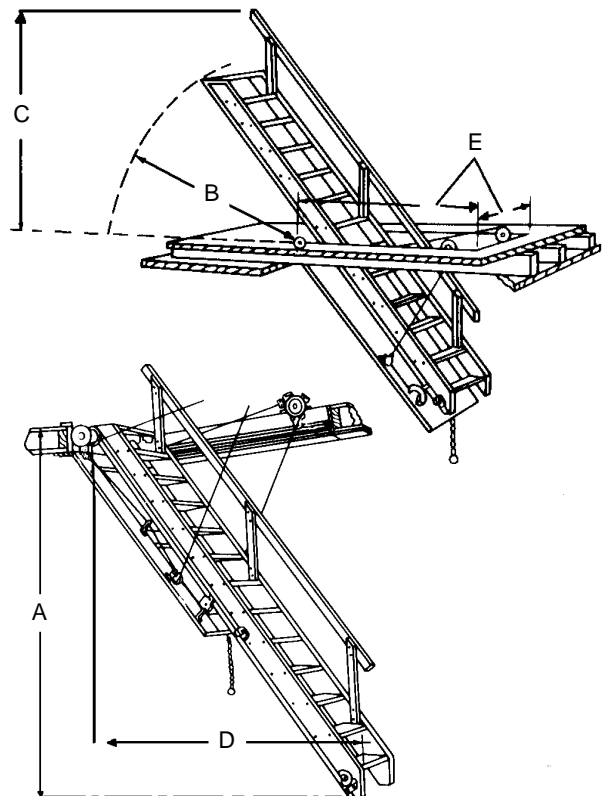

Check Model Size

Be sure to check the Radius ABOVE (B) Plumb Height ABOVE (C) and Run BELOW (D) to make sure your available space is adequate for proper installation and operation. See Fig. 1 and Table 1.

TABLE 1

Size	(A) Floor To Floor	(B) Radius Above	(C) Plumb Height	(D) Run Below
1	7'7" – 7'10"	4'4"	3'2"	6'5"
2	7'11" – 8'4"	4'11"	3'8"	6'10"
3	8'5" – 8'10"	5'7"	4'1"	7'3"
4	8'11" – 9'4"	6'2"	4'6"	7'7"
5	9'5" – 9'10"	6'4"	4'9"	8'0"
6	9'11" – 10'4"	6'8"	5'0"	8'4"
7	10'5" – 10'10"	7'0"	5'3"	8'9"
8	10'11" – 11'4"	7'6"	5'5"	9'2"
9	11'5" – 11'10"	7'8"	5'10"	9'6"
10	11'11" – 12'4"	8'1"	6'1"	9'10"
11	12'5" – 12'10"	8'6"	6'4"	10'3"

Check Opening Dimensions (E)

The Bessler Stairway will work with almost any ceiling thickness of 7-1/2" or more. If more than 18", call factory for additional instructions. Review Figure 1 on page 3 and refer to Table 2 below to make sure the size of the rough and finished openings are correct for your specific model.

TABLE 2

Sizes	Rough Opening Inside Dim.	Finish Opening Inside Dim.	Guide Frame Slide Bar Inside Width
1-3	2'8" x 6'0"	2'6" x 5'10"	18-7/16"
4	2'8" x 6'2"	2'6" x 6'0"	18-7/16"
5	2'8" x 6'6"	2'6" x 6'4"	18-7/16"
6	2'8" x 6'10"	2'6" x 6'8"	18-7/16"
7	2'8" x 7'2"	2'6" x 7'0"	18-7/16"
8	2'8" x 7'5"	2'6" x 7'3"	18-7/16"
9	2'8" x 7'8"	2'6" x 7'6"	18-7/16"
10	2'8" x 7'11"	2'6" x 7'9"	18-7/16"
11	2'8" x 8'2"	2'6" x 8'0"	18-7/16"

Outside ladder width (measured across back) should be 18-7/8" on all sizes.

Header Guide Frame

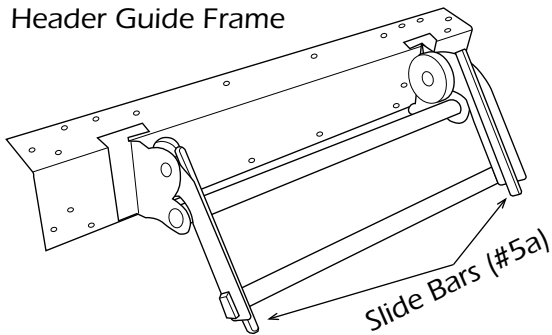

Door Panel Brackets

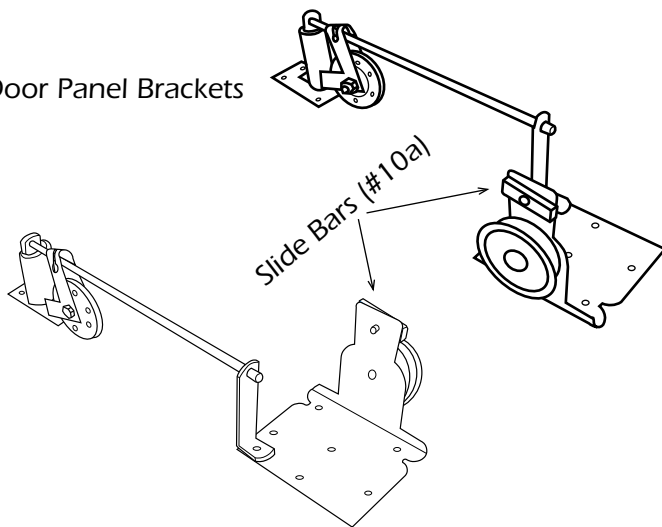

Check Guide Frame Slide Bars

Check Header Guide Frame Slide Bars (#5a) and Door Panel Bracket Slide Bars (#10a) for alignment. The Model 100's slide bars should be 18-7/16" inside to inside and parallel to each other. Check measurement at each end of the bars. You may adjust the slide bars by bending the bracket slightly in or out if needed.

Preparation Of The Rough Opening

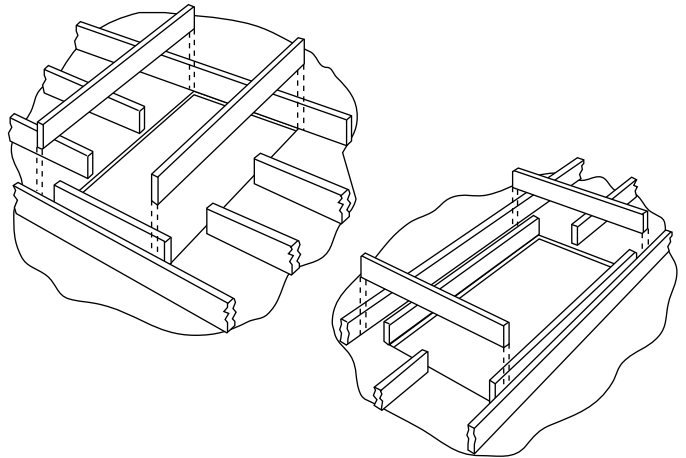

Typical construction for perpendicular and parallel joists.

Step 1

Prepare the rough opening to the size shown in Table 2 for the size of your stair. Double headers may be needed in certain circumstances. Use standard carpentry practices when building rough opening and check your local building code for correct configurations.

Preparation Of The Finished Opening

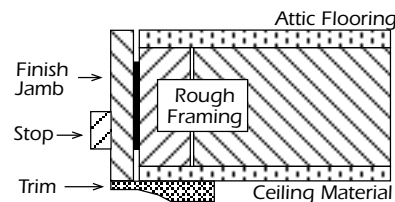

Step 2

NOTE: Jamb is not furnished by Bessler Stairway. See Table 2 for dimensions for your model size. Build the finished jamb on the ground. Finished jamb should be constructed from 1" dressed lumber (depth will vary depending on ceiling thickness). Depth of jamb should be such that it fits flush with ceiling and attic flooring.

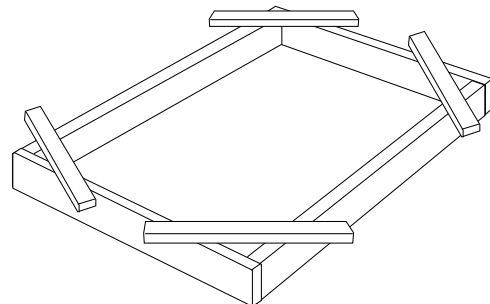

Step 3

After sized correctly and squared, secure jamb by nailing slats across the four corners, allowing slats to overhang jamb edges. Lift into ceiling and allow to hang from attic floor by the slats. Fasten securely to ceiling joists with 16 penny or larger nails or 1/4 x 3" or larger lag screws. Remove slats. Trim door opening on ceiling using standard materials and practices.

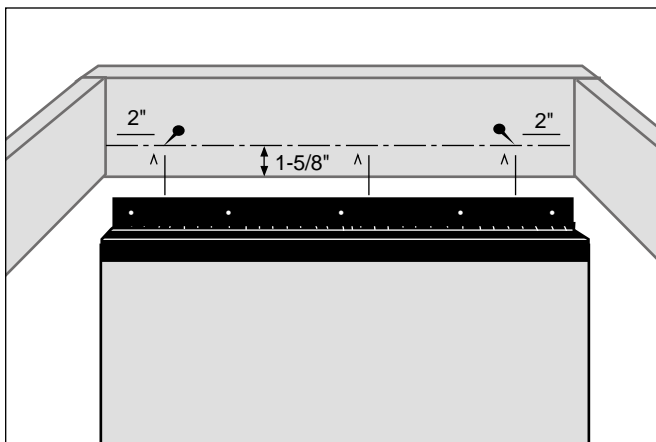
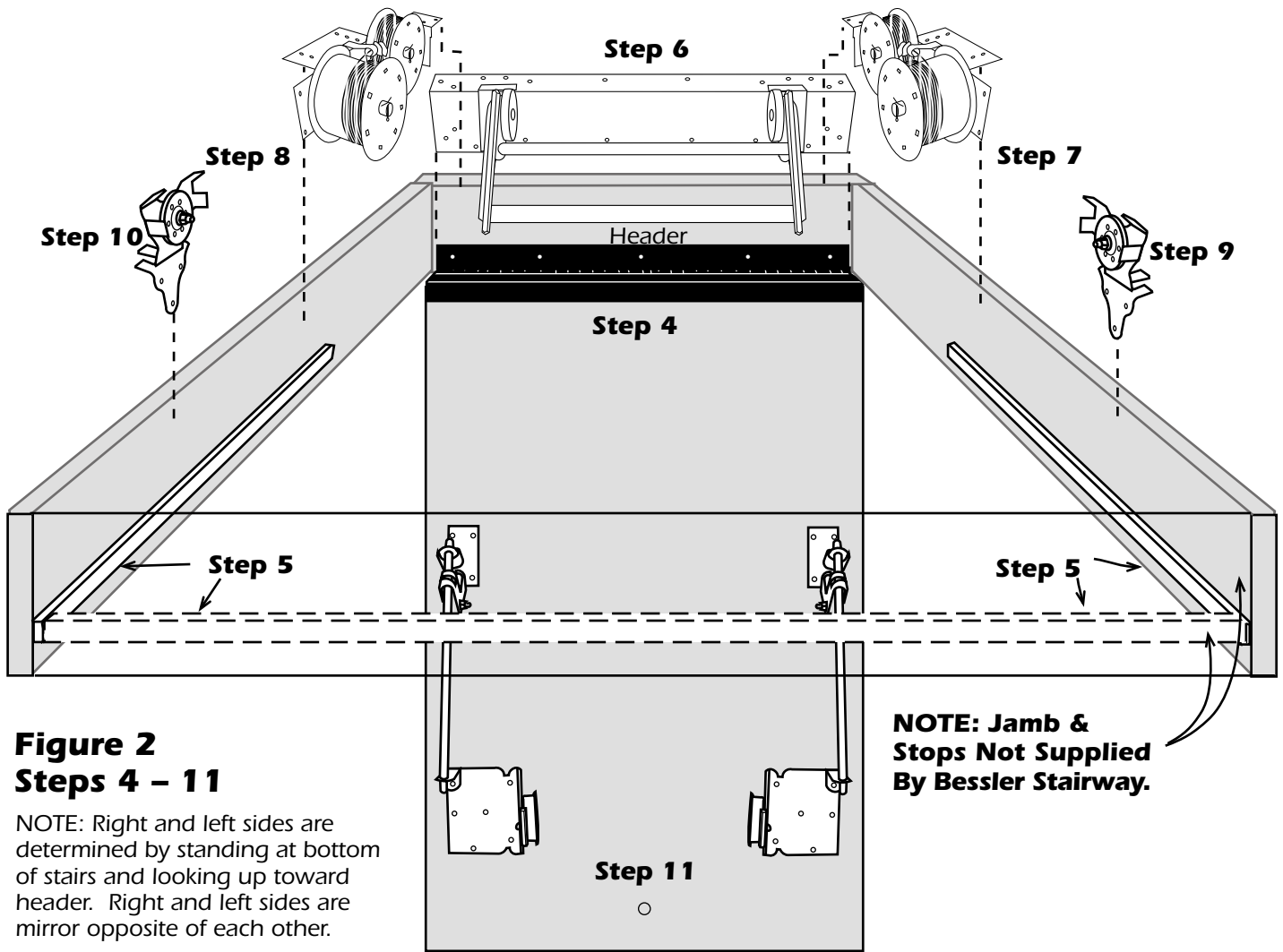

Step 4

On selected header, draw a line 1-5/8" up from the bottom of the door jamb. Then, approximately 2 inches from each corner, partially drive 2 small nails on this line for a guide. Hold Door Panel (#15) upright with the loose leaf of the offset piano hinge against the nails. Center the door panel in the finished jamb, predrill two holes and drive two 1" screws to hold the door. Now check the swing of the door to make sure it does not bind in the finished jamb. Make adjustments in the jamb as necessary. Install screws in the remaining three holes and remove 2 positioning nails. Make sure screw heads are screwed in flush.

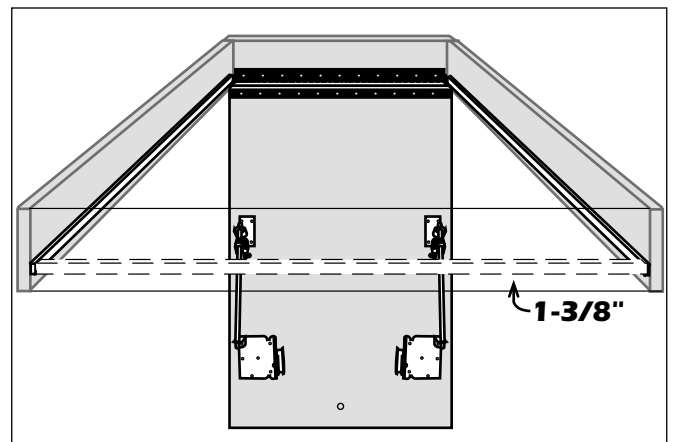

Step 5

Install 3/8" x 1-1/4" door stops (not supplied) on remaining three sides at 1-3/8" from bottom. Door stop may need to stop at Spring Drum Assemblies or be trimmed to allow placement of Spring Drum Assemblies in steps 7 and 8.

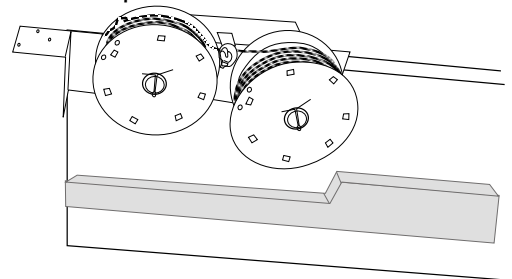

Installing Hardware

The factory has sent two sizes of pan head screws. The 1" screws are to be used to attach metal to wood. The 1-1/4" screws are to be used to attach wood to wood. DO NOT USE 1-1/4" SCREWS AT THIS TIME.

Have on hand in attic: both Left and Right Spring Drum Assemblies (#6), two Jamb Brackets (#9) and Header Guide Frame (#5).

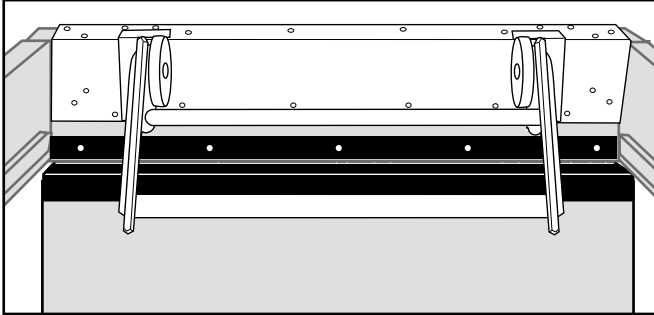

Step 6

Hook the short angle of the Header Guide Frame (#5) on top of the attic floor in the center of the finished opening directly above the door hinge. Predrill all holes in the floor and jamb side and fill with 1" screws, LEAVING THE THREE HOLES IN EACH END OF THE FLOOR SIDE TO BE USED LATER. After all screws have been tightened, check spacing of slide bars to be sure they still measure $18\frac{7}{16} \pm 1/32$ ".

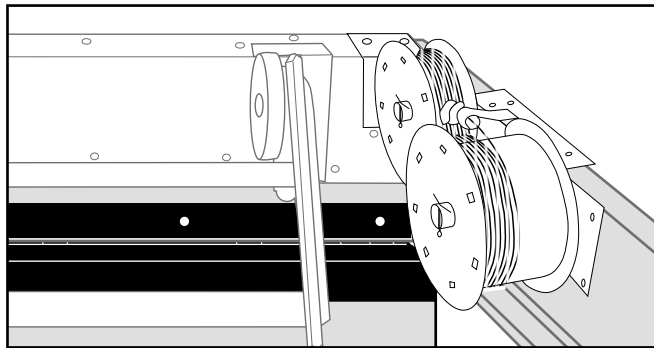

Step 7

As you face the door, install Right Spring Drum Assembly (#6) in the corner against the selected header, matching the three holes in the end of the drum mounting bracket to those left open in the guide frame. PREDRILL ALL HOLES AND ATTACH WITH 1" SCREWS. LEAVE CABLES ALONE FOR NOW.

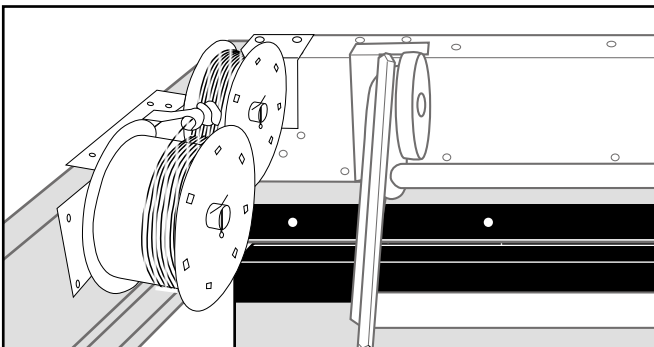

Step 8

Install Left Spring Drum Assembly (#6) in the same manner as the Right Assembly.

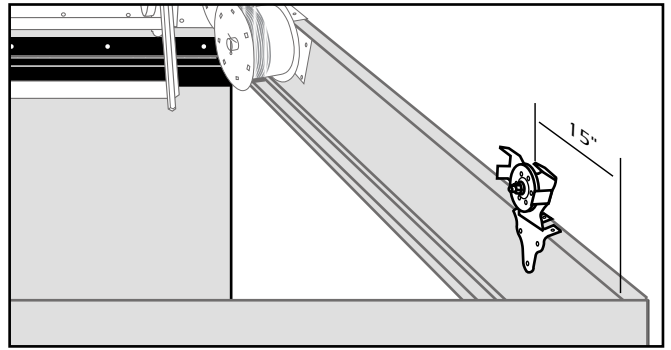

Step 9

Mount the right side Jamb Bracket (#9) so that its centerline is 15" from the well end opposite the door and the tabs are flush with the attic floor. PREDRILL THE HOLES AND ATTACH WITH 1" SCREWS.

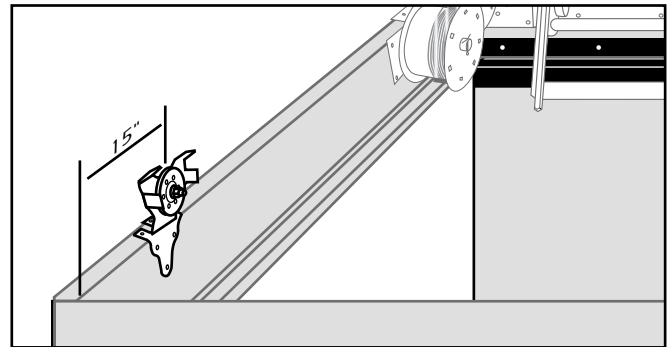

Step 10

Mount the left side Jamb Bracket (#9) in the same manner as the right side.

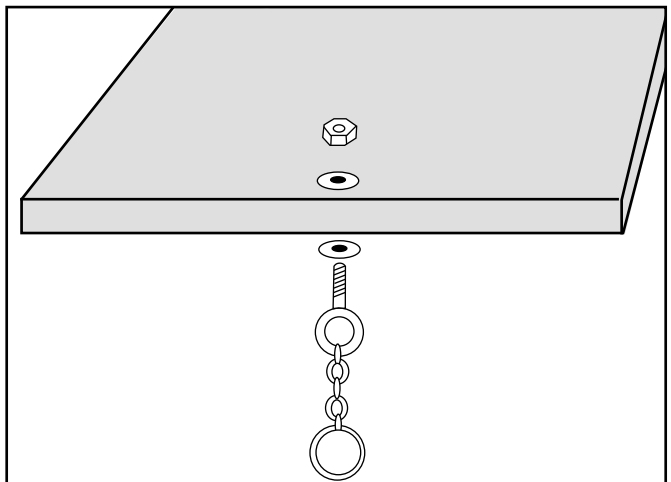

Step 11

Install the Pull Chain (#17) in the door using the 3/16" x 2" eyebolt, #10 x 24 nut, two ladder rod washers and chain. Spread the eyelet just enough to insert the round portion of the chain. Close up the eyelet, then insert eyebolt through 1 washer and door. Add a washer on the threaded end and tighten nut with 3/8" nut driver. You can wait to attach pull ring later when you adjust chain for length.

This may be a good place to double-check the swing of the door to insure that it doesn't bind against the finished jamb.

Assemble Stringers and Treads:

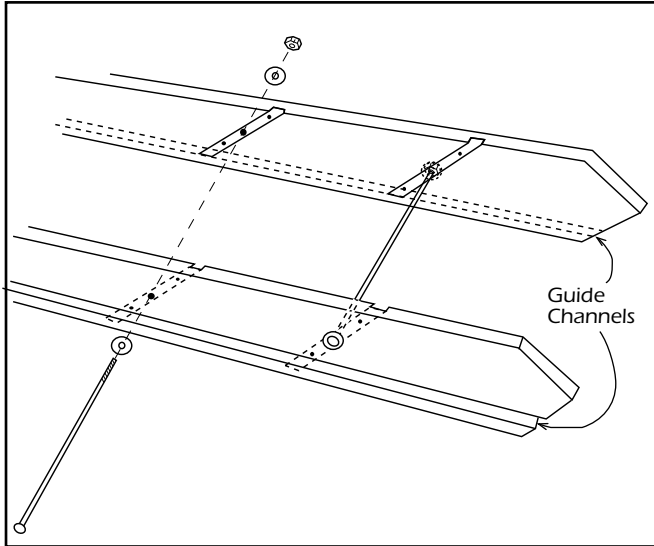

Step 12

Lay out stringers on ground or saw horses with the guide channels on the bottom and facing outward. Align the middle holes at each gain, insert ladder rods through washers and drive through middle holes of both stringers. Place a washer on the threaded end and run a nut on each ladder rod until two full threads are showing past the nut. **DO NOT INSERT TOP THREE RODS AT THIS TIME.**

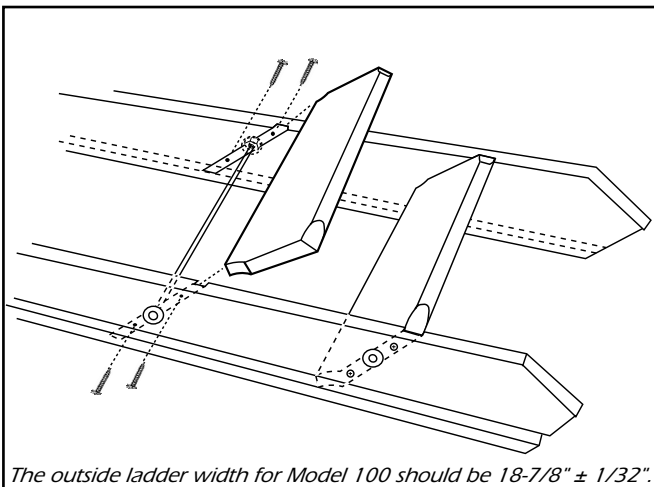

The outside ladder width for Model 100 should be 18-7/8" ± 1/32".

Step 13

Spread the stringers apart. The treads are precision cut to act as spacers to hold the outside width of the stairs at a constant measurement (18-7/8" ± 1/32") and should fit snugly into the gains, groove side up. You may have to use a mallet to install the treads all the way into the gains. Start at the bottom of the stairs and **INSTALL ALL BUT THE TOP THREE TREADS.** NOTE: THE TOP TREAD IS DEEPER THAN OTHERS. As you install the treads, check the outside width of the stairs, both front and back, to maintain the correct measurement (18-7/8" ± 1/32").

At first, flush the chamfered edge with the front of the stringer and make sure the treads are seated all the way into the gains. Then, if needed, try sliding the treads in or out, front to back, about 1/8" to achieve measurement. You are working with a pine wood product. As you know, pine can vary slightly, even when milled.

Attach treads to stringers with four 1-1/4" screws. For easy assembly, drill treads with a 1/8" bit through the holes in the stringers. Tighten ladder rod nuts andpeen the threaded end of the rods to keep nut from coming off. The outside ladder width for Model 100 should be 18-7/8" ± 1/32".

Installing The Stair Section

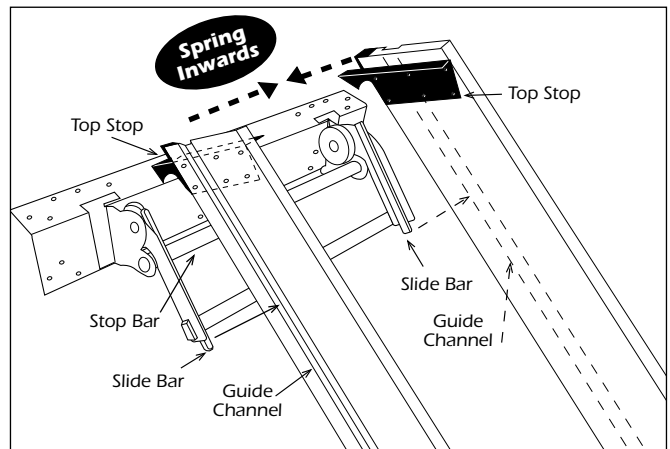

Step 14

With one person in the attic to guide stairs, lift the stairs up to the header so the top stops are above the slide bars on the Header Guide Frame. "Spring" in the top of the stairs and insert slide bars of Header Guide Frame (#5) into the guide channels on the outside of the stringers just below the riveted top stops. Make sure the slide bars are seated in the guide channels. (DO NOT FORCE the slide bars of either the Door Panel Frame or Header Guide Frame over the edge of the ladder as this may spread the bars or damage the brackets.

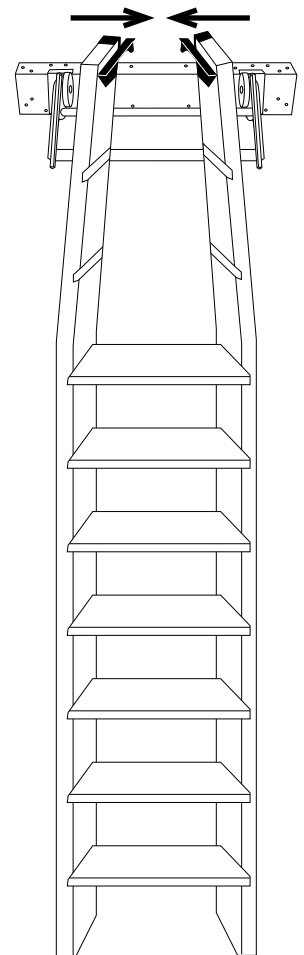

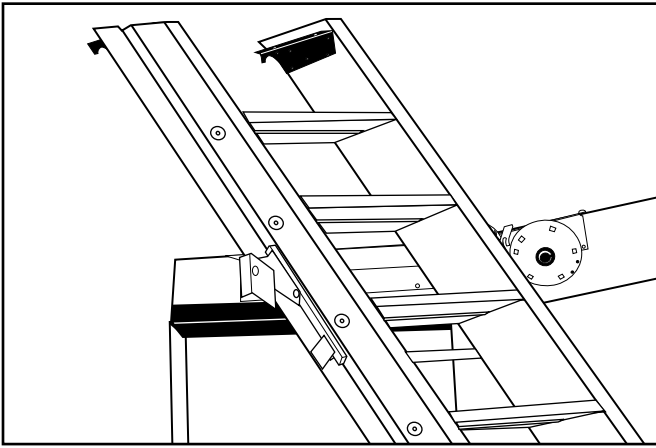

Step 15A

To install the top three treads, have helper push and hold the stairs up to where their position on the stringers clears the attic floor. Install the rods and treads of the second and third steps in the same manner as the other treads (Steps #12 & #13).

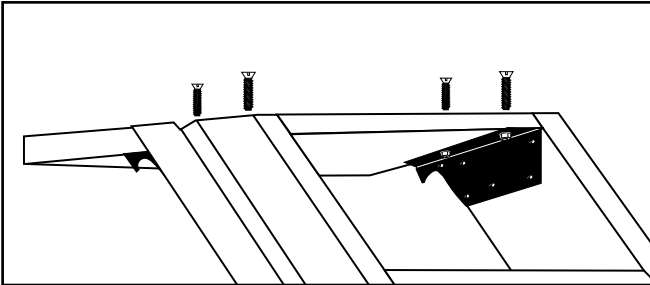

Step 15B

The top tread is deeper, 12-5/16". Place onto the Top Stop brackets (#20) and attach with (4) 1/4-20 x 1-1/4" flat head screws with keps nuts.

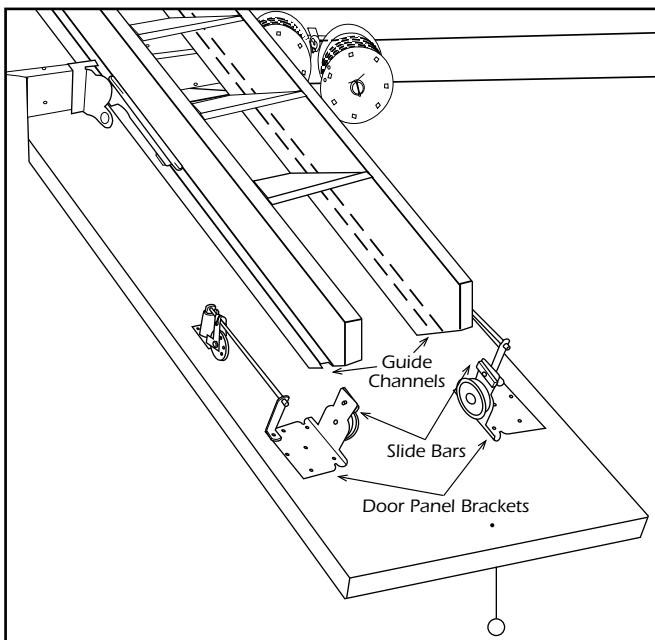

Step 16

Remove the Catch Lock and Bottom Stop and slide the stairs above the Door Panel Brackets. Then pull ladder down until the slide bars enter the guide channels. Lower stairs to floor and replace catch lock and bottom stop.

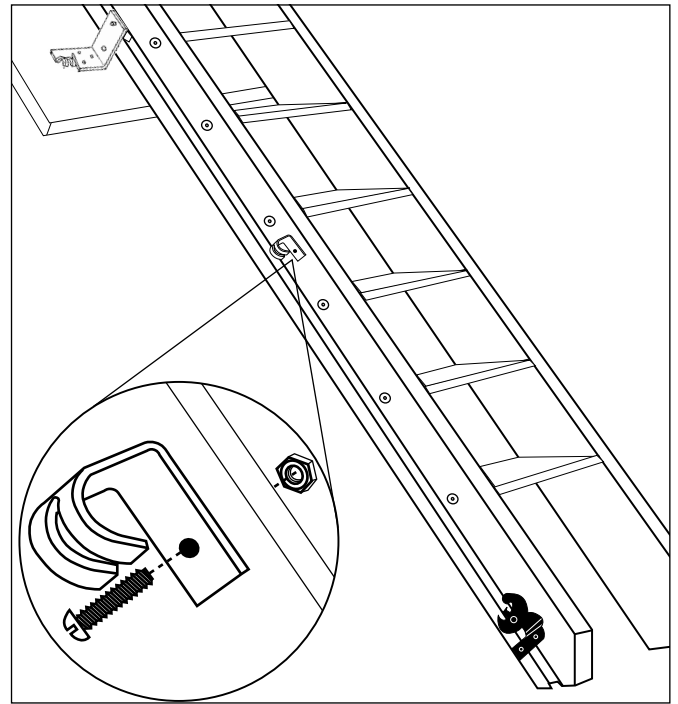

Step 17

Fasten Cable Holders (#13) to both stringers where holes are predrilled near fourth tread from bottom. Use a 1/4"-20 x 1-1/4" R.H. machine screw.

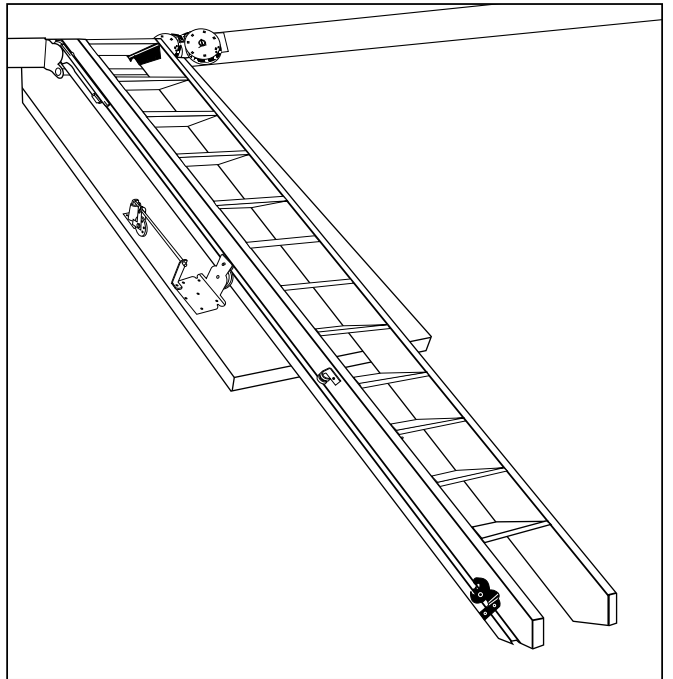

Stringing The Cables

Step 18

Pull stairs all the way down until the top tread is level with the attic floor and the Top Stops engage the round tube on the Guide Frame. The Top Stops engaging the round tube is important as this provides the load bearing capability of the top portion of the ladder. Now you are ready to hook up the cables.

Both cables on the Spring Drum Assembly are attached to a shipping fork. The drums are shipped with tension to keep cables secure. **DO NOT UNHOOK FROM SHIPPING FORK UNTIL READY TO STRING.** **WARNING:** DO NOT LET CABLE SLIP FROM YOUR HAND SINCE SUDDEN RELEASE OF TENSION CAN BREAK OR BACK-WIND THE SPRING AND CABLE TRAVEL MAY CAUSE PERSONAL INJURY.

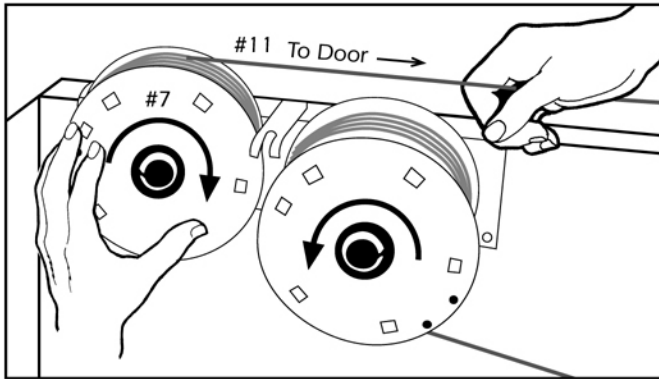

Step 19

Start with the Door Panel Cable (#11) by carefully removing the cable from the shipping fork. **CAUTION:** Door cables come with tension for shipping purposes only. Back off tension on Door Drum (#7) slowly until all tension is released. Add initial tension by rotating the drum three complete turns in the direction the cable comes off the drum, leaving cable still completely wrapped around drum.

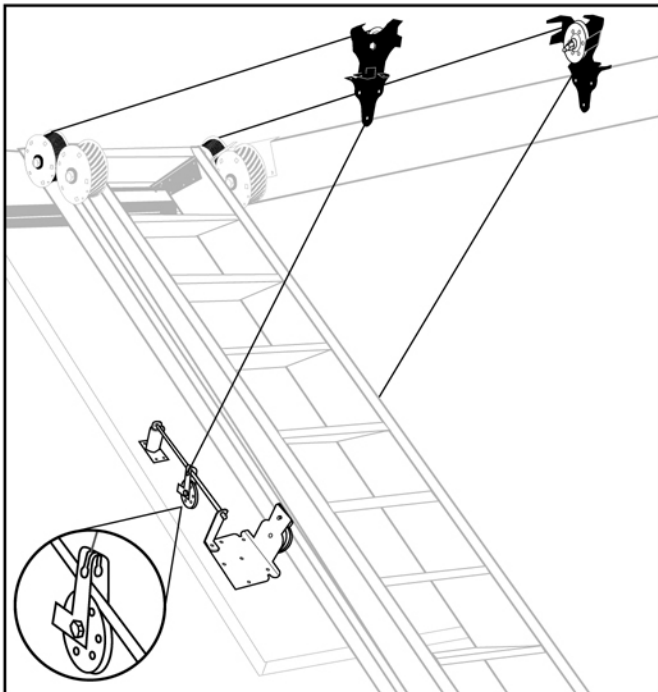

Step 20

Grasp the cable firmly and pull the cable (allowing drum to turn) parallel to the attic floor and thread the cable through the idler wheel on the Jamb Bracket (#9) and down to the keyhole slot in the Sheave Wheel (#19) on the Door Panel Bracket (#10).

Make certain the swedged cable stop button is securely fastened in the keyhole slot and will not pull out. Repeat for other side.

NOTE: Refer to Step 25 for final adjustment of tension.

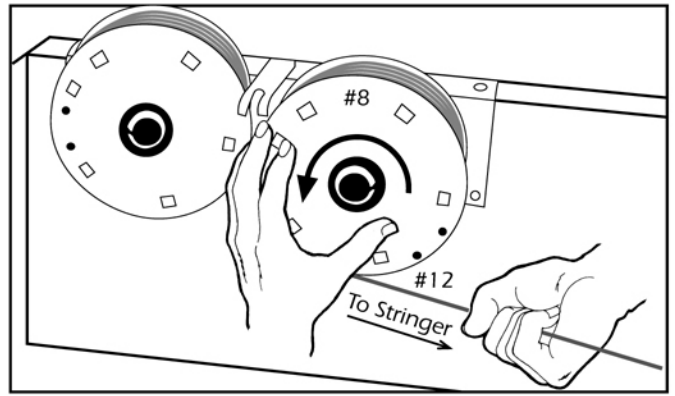

Step 21

Next, install the Stringer Cables (#12). Back off tension on Stringer Drum (#8) slowly until all tension is released. Add initial tension by rotating the drum three to four complete turns for smaller stairs (sizes 1 – 4). Larger stairs (sizes 5 – 11) have stronger springs and may require more than 4 turns. Rotate drum in the direction the cable comes off the drum, leaving cable still completely wrapped around drum.

WARNING: DO NOT LET CABLE SLIP FROM YOUR HAND SINCE SUDDEN RELEASE OF TENSION CAN BREAK OR BACK-WIND THE SPRING AND CABLE TRAVEL MAY CAUSE PERSONAL INJURY.

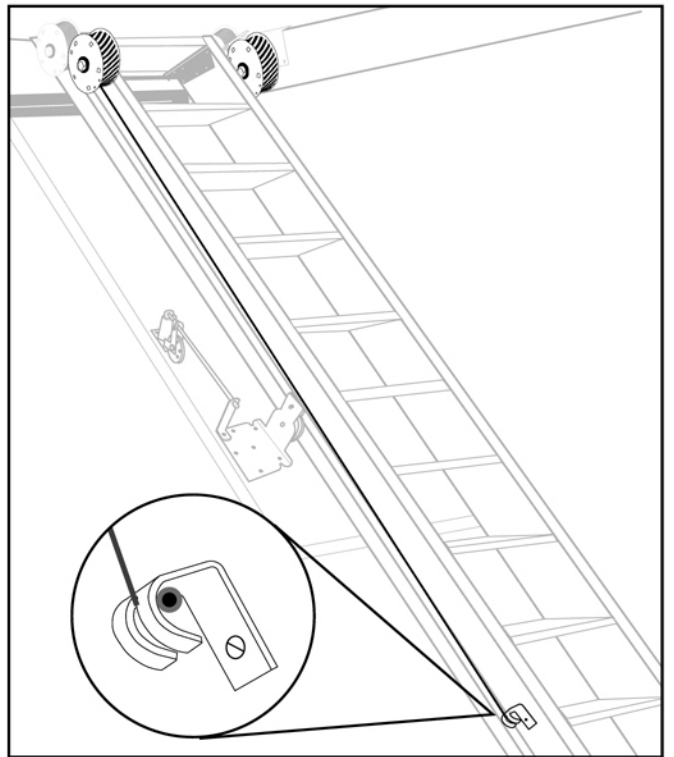

Step 22

Keeping cable **ALIGNED** with drum, pull the cable (allowing drum to turn) down and hook to Cable Holder (#13) on stringer. Repeat for left side. (Left side is mirror opposite of right side.) **NOTE:** Refer to Step 25 for final adjustment of tension.

Attach Handrail

Step 23

Top post should be mounted plumb to inside of stringer and resting on second tread from the top using three 1-1/4" screws. Attach handrail about 4" past top post with two 1-1/4" screws. Go to the other end and attach bottom post to inside of stringer with post resting on bottom tread and plumb under the handrail, attach with two 1-1/4" screws. Position other posts at equal intervals on stairs. There are three posts for sizes 1 – 4 and four posts for sizes 5 – 7. Handrail may be attached to either side and further down the stairs, depending on Plumb Height and customer's wants. Make sure horns of posts are covered by the handrail. Always use handrail when walking up and down stairways. **HANDRAIL IS FOR BALANCE PURPOSES ONLY AND IS NOT LOAD BEARING.**

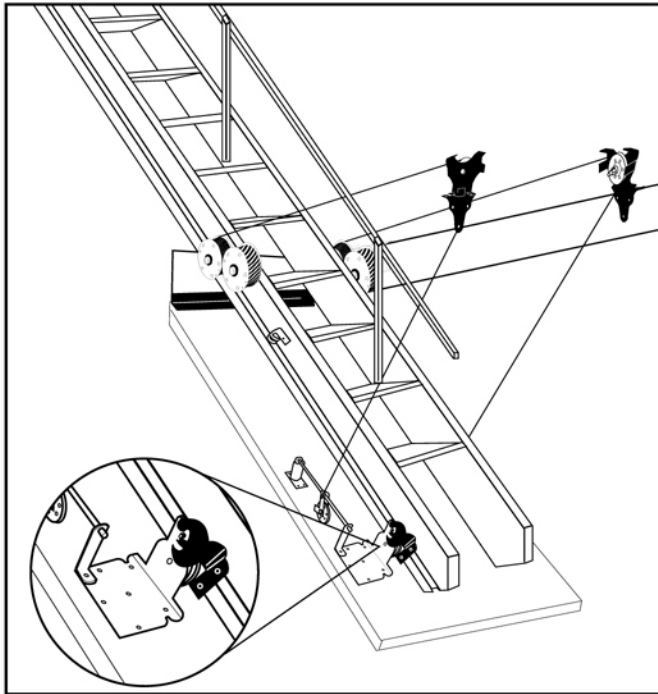
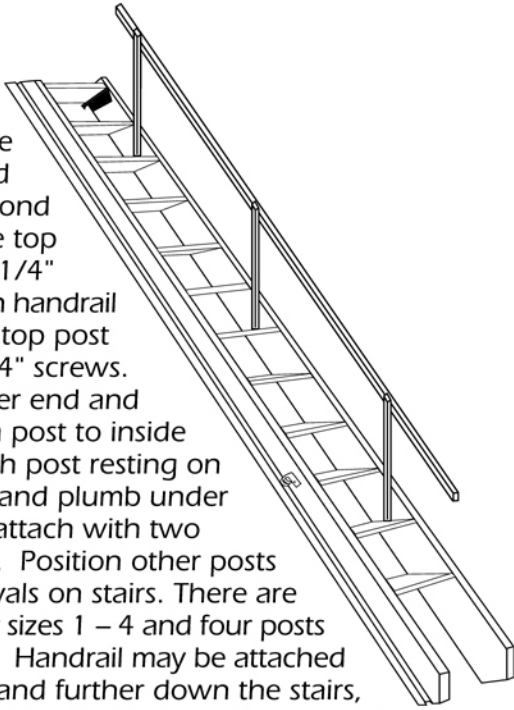

Step 24

Raise the stairs to the stored but still open position on door panel. Make sure Catch Lock (#14) has engaged the Catch Pin by pulling the stairs back about 1/2". **DO NOT LET THE DOOR SLAM.** Slamming the door may cause damage to the Stringer Guide Channel or tear the Door Guide Frame (#10) from the door. **NOTE:** Refer to Step 25 for final adjustment of tension.

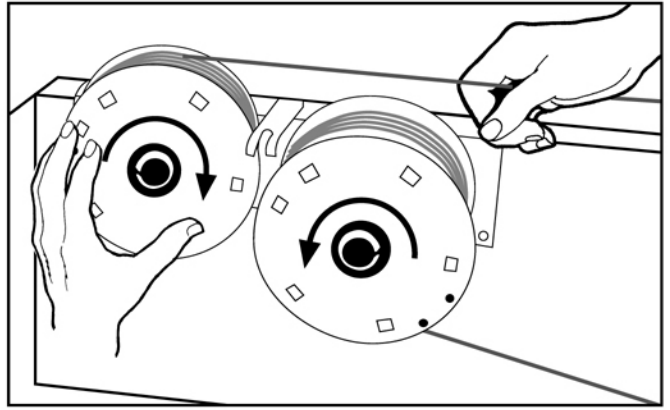

Right Hand Spring Drum Assembly illustrated. Left Hand Assembly is mirror opposite of right.

Adjust Spring Tension

Step 25

Always work toward using the minimum amount of tension to do the job. On the average, one complete turn of the drum will add or reduce approximately 2 lbs. of lift.

Stair Tension

Have enough tension for minimum force to slide the stairs up to the stored position, **but not so much tension that the stairs creep up when resting on the floor.** This could cause accidental tripping. Too little tension may allow stairs to slide too forcefully to floor or may cause stairs to feel heavy.

Door Panel Tension

Enough tension should be used to close the door very slowly without slamming, but enough to hold the door against the stops.

Add tension by adding more turns of cable. Take the end of the cable loose from the cable holder and slowly let it wrap up on the drum. While you still have a length of cable in your hand, hold the drum firmly and wrap additional cable around drum as needed. Return cable to cable holder. Repeat for other side.

Reduce tension by unwrapping additional cable. Take the end of the cable loose from the cable holder and slowly let it wrap up on the drum. Hold the drum firmly and unwrap additional cable from drum as needed. Return cable to cable holder. Repeat for other side.

WARNING: DO NOT LET CABLE SLIP FROM YOUR HAND SINCE SUDDEN RELEASE OF TENSION CAN BREAK OR BACK-WIND THE SPRING AND CABLE TRAVEL MAY CAUSE PERSONAL INJURY.

Trouble Shooting

If stair section is jumping out of track:

- Check width of stairs.
- Check dimension between slide bars.
You may adjust the slide bars by bending the bracket slightly in or out as needed.
(see Table 2, pg 4)

If stair section is hard to move or binding:

- Make sure slide bars are in the guide channel over the entire length of travel.
- Lubricate guide channel with grease or wax.
- Look for gouge marks and check width of stairs at that point. (see Table 2, pg 4)
- Check seating of treads and tightness of ladder rods.

If cable runs off of drum when moving stair section:

- Check to see if stair is centered in opening.
- Check for proper alignment of hardware.
- Check for alignment and plumbness of jamb.
Mounting brackets can be shimmed to correct minor misalignment.

If stair section comes down too fast:

- Add spring tension to stringer drum (#8). Refer to Step 25 to adjust tension.

If stair section "creeps up" from down position:

- Reduce spring tension to stringer drum (#8). Refer to Step 25 to adjust tension.

If Door Panel fails to close:

- Add spring tension to panel drum (#7). Refer to Step 25 to adjust tension.
- Make sure screw heads are seated against hinge.
- Check for foreign debris.
- Check for ladder hitting something in attic.
- Check clearance in attic for ladder to go all the way to its resting position.

If Door Panel slams shut:

- Reduce spring tension to panel drum (#7). Refer to Step 25 to adjust tension.

If you break or back-wind a spring:

- CALL THE FACTORY.

WARNING: The spring inside the drum, even though broken or back-wound, is under EXTREME compression. DO NOT OPEN THE SPRING DRUM. Call the factory for instructions before returning to the address on back for repairs.



3807 Lamar Ave. ■ Memphis, TN 38118
901-360-1900 ■ Fax 901-795-1253
www.bessler.com ■ E-Mail: bessler@bessler.com