

# **Assembly & Operation Instructions**

## **Models 30, 40 & 70**

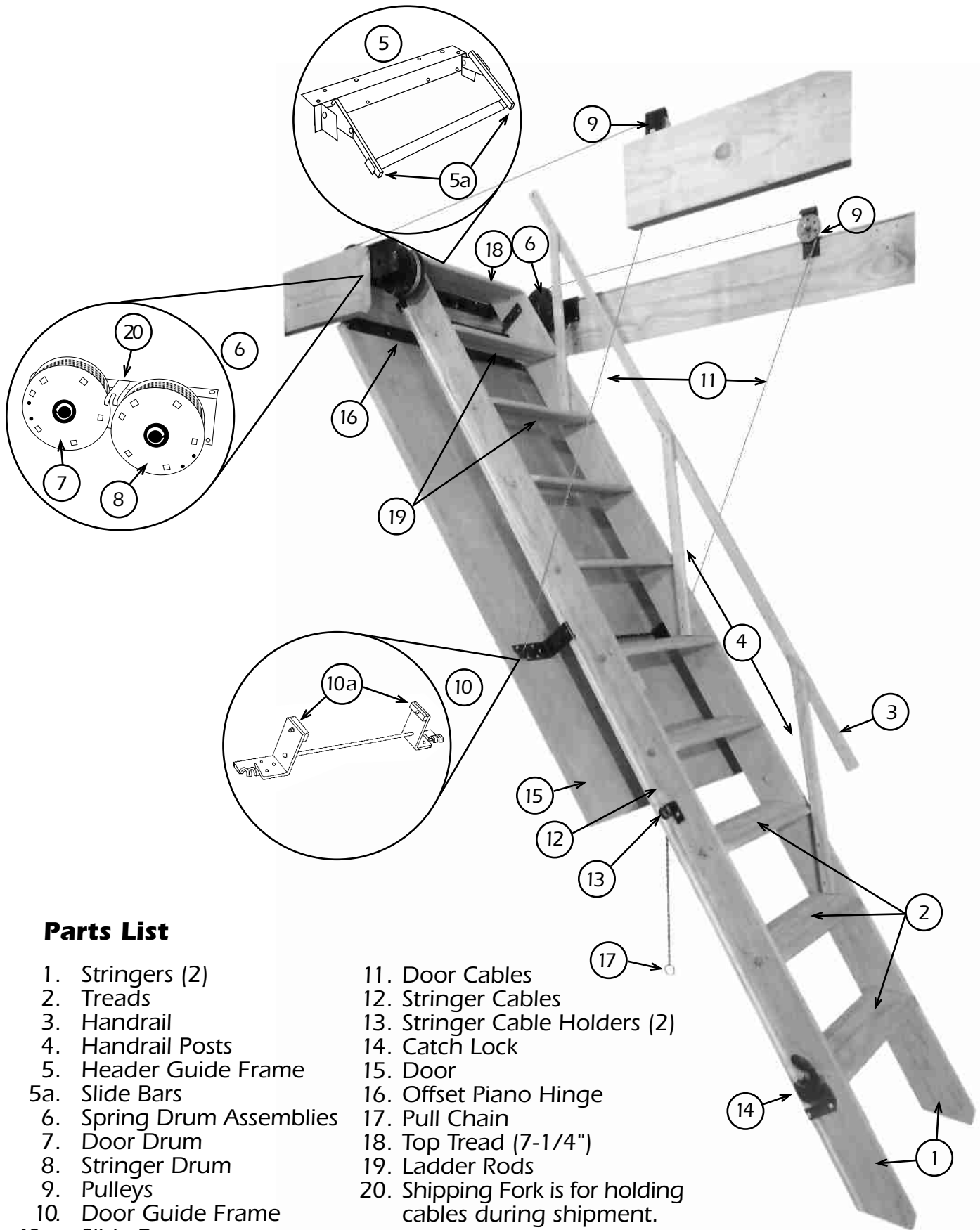

# Bessler Assembly & Operation Instructions For Models 30, 40 & 70



## Parts List

- |                           |  |
|---------------------------|--|
| 1. Stringers (2)          | 11. Door Cables  |
| 2. Treads                 | 12. Stringer Cables                                      |
| 3. Handrail               | 13. Stringer Cable Holders (2)                           |
| 4. Handrail Posts         | 14. Catch Lock   |
| 5. Header Guide Frame     | 15. Door   |
| 5a. Slide Bars            | 16. Offset Piano Hinge                                   |
| 6. Spring Drum Assemblies | 17. Pull Chain   |
| 7. Door Drum              | 18. Top Tread (7-1/4")                                   |
| 8. Stringer Drum          | 19. Ladder Rods  |
| 9. Pulleys                | 20. Shipping Fork is for holding cables during shipment. |
| 10. Door Guide Frame      |  |
| 10a. Slide Bars           |  |

*\*Appearance of parts may vary slightly according to specific model.*

## Before You Install.

To make sure you receive the best performance from your Bessler, please take a few moments to familiarize yourself with all of the parts and guidelines. Seek professional help if not experienced in carpentry. Example: An experienced finish carpenter with good help should easily install the door jamb and stairs and adjust for operation in four hours or less. Time is directly dependent on skill and the understanding of these instructions. This is a stairway; take your time, work safe and eliminate liabilities.

**Figure 1**

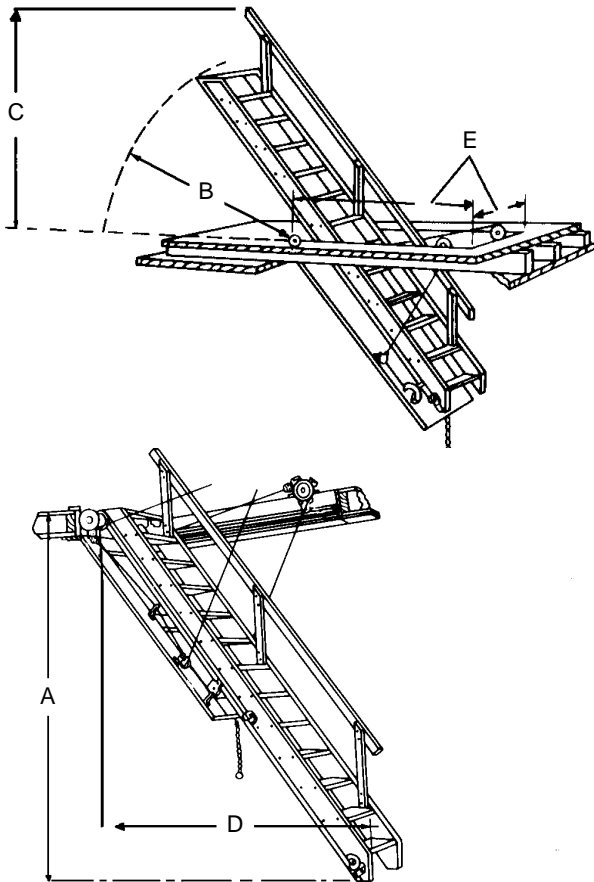

## Check Model Size

Be sure to check the Plumb Height (C) and Radius ABOVE (B) the header. Review Figure 1 above and refer to Table 1 to make sure the size of your specific model fits within the specified measurements.

**TABLE 1**

| Size | (A) Floor To Floor | (B) Radius Above | (C) Plumb Height | (D) Run Below |
|------|--------------------|------------------|------------------|---------------|
| 1    | 7'7" – 7'10"       | 4'1"             | 2'11"            | 5'4"          |
| 2    | 7'11" – 8'4"       | 4'8"             | 3'5"             | 5'8"          |
| 3    | 8'5" – 8'10"       | 5'3"             | 3'11"            | 6'0"          |
| 4    | 8'11" – 9'4"       | 5'10"            | 4'5"             | 6'4"          |
| 5    | 9'5" – 9'10"       | 5'10"            | 4'6"             | 6'8"          |
| 6    | 9'11" – 10'4"      | 6'6"             | 5'1"             | 6'11"         |
| 7    | 10' 5" – 10'10"    | 7'1"             | 5'5"             | 7'4"          |

## Check Opening Dimensions (E)

The Bessler Stairway will work with almost any ceiling thickness of 6-1/4" or more. If more than 14", call factory for additional instructions. Review Figure 1 and refer to Table 2 to make sure the size of the rough and finished openings are correct for your specific model.

**TABLE 2**

| Model         | Rough Opening Inside Dim. | Finish Opening Inside Dim. | Guide Frame Slide Bar Inside Width |
|---------------|---------------------------|----------------------------|------------------------------------|
| #30 sizes 1-4 | 22-1/2" x 5'6"            | 22-1/2" x 5'6"             | 16-5/8"                            |
| #30 sizes 5-7 | 22-1/2" x 6'0"            | 22-1/2" x 6'0"             | 16-5/8"                            |
| #40 sizes 1-4 | 2'2" x 5'8"               | 2'0" x 5'6"                | 16-5/8"                            |
| #40 sizes 5-7 | 2'2" x 6'2"               | 2'0" x 6'0"                | 16-5/8"                            |
| #70 sizes 1-4 | 2'8" x 5'8"               | 2'6" x 5'6"                | 18-7/16"                           |
| #70 sizes 5-7 | 2'8" x 6'2"               | 2'6" x 6'0"                | 18-7/16"                           |

## Check Parts

You should have three cartons:

Carton No. 1 – Hardware, fasteners, treads, ladder rods and these instructions.

Carton No. 2 – Door with offset piano hinge attached (do not remove) and is predrilled for mounting the Door Guide Frame.

Carton No. 3 – Two stringers, one handrail and handrail posts.

Check all parts against the Parts List on Page 2.

**NOTE:** FINISHED JAMB OR CLOSING JAMB AND DOOR STOPS ARE NOT PROVIDED BY BESSLER.



#10 x 1" P.H. Screws



#10 x 1-1/4" P.H. Screws

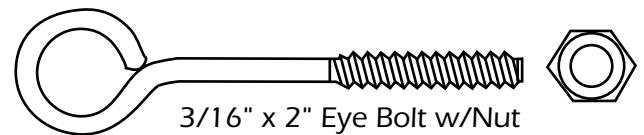

3/16" x 2" Eye Bolt w/Nut



Ladder Rods  
Models 30 & 40: 17-5/16"  
Model 70: 19-1/4"

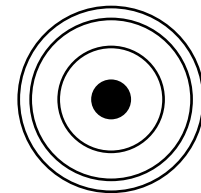

1" Ladder Washers



#10 Hex Nuts

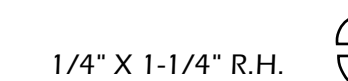

1/4" X 1-1/4" R.H.

Machine Screw And Lock Nut

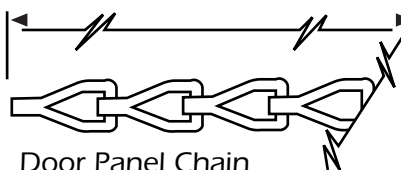

Door Panel Chain

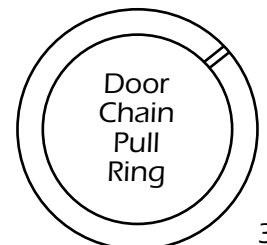

Door Chain Pull Ring

Header Guide Frame

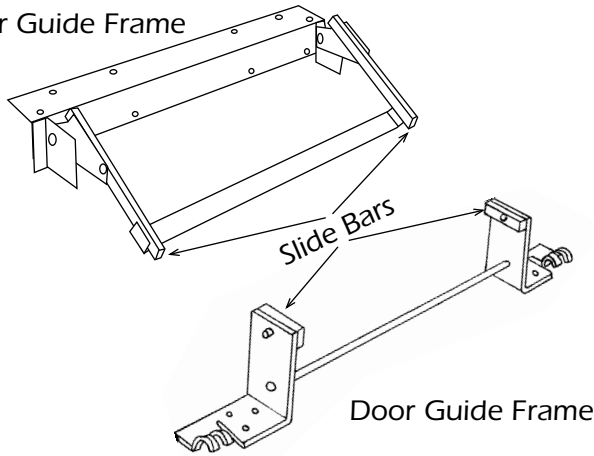

**Check Guide Frame Slide Bars**

Check Header Guide Frame (#5) and Door Guide Frame (#10) Slide Bars for alignment. The Models 30 & 40's slide bars should be 16-5/8" inside to inside and parallel to each other. Model 70 should be 18-7/16". You may adjust the slide bars by bending the bracket slightly in or out if needed.

**NOTE**—Instructions for Model 30 varies slightly from Models 40 & 70 in the preparation of the opening. Be sure of the model you are installing and follow appropriate directions.

**Step 1—MODEL 30 ONLY**

**Preparation Of The Rough Opening**

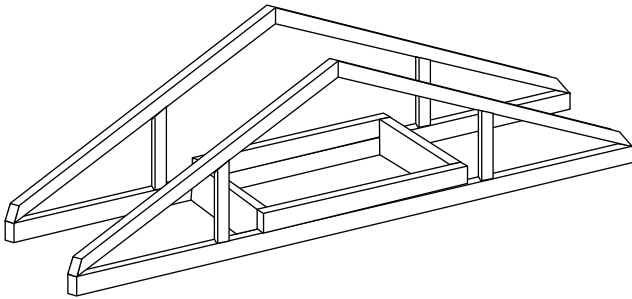

The Model 30 is specially designed to fit between 24" on center truss ceilings. The rough and finished opening will be the same, provided the trusses are placed on 24" centers. This stair is designed to be installed in ceilings that are a minimum of 6-1/4" and maximum of 15" in depth. If the truss cord is made from 2 x 4's, you will have to shim the cord to a minimum depth of 6-1/4", making certain that all four corners of the finished opening are square (90°). Trim door opening on ceiling using standard materials and practices.

**MODEL 30 Proceed to Step 4.**

**Steps 1-3 –MODELS 40 & 70 ONLY  
Preparation Of The Rough Opening**

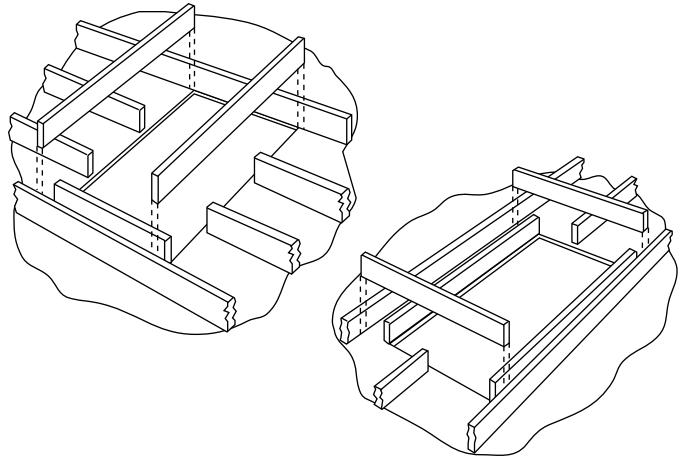

*Typical construction for perpendicular and parallel joists.*

**Step 1 – Models 40 & 70**

Prepare the rough opening to the size shown in Table 2 for the model and size of your stair. Double headers may be needed in certain circumstances. Use standard carpentry practices when building rough opening and check your local building code for correct configurations.

**Preparation Of The Finished Opening**

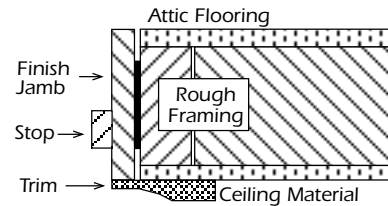

**Step 2 – Models 40 & 70**

**NOTE:** Jamb is not furnished by Bessler Stairway. See Table 2 on page 3 for dimensions for your model and size. Build the finished jamb on the ground. Finished jamb should be constructed from 1" dressed lumber (depth will vary depending on ceiling thickness). Depth of jamb should be such that it fits flush with ceiling and attic flooring.

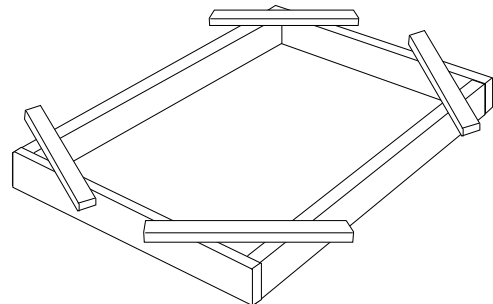

**Step 3 – Models 40 & 70**

After sized correctly and squared, secure jamb by nailing slats across the four corners, allowing slats to overhang jamb edges. Lift into ceiling and allow to hang from attic floor by the slats. Fasten securely to ceiling joists with 16 penny or larger nails or 1/4 x 3" or larger lag screws. Remove slats. Trim door opening on ceiling using standard materials and practices.

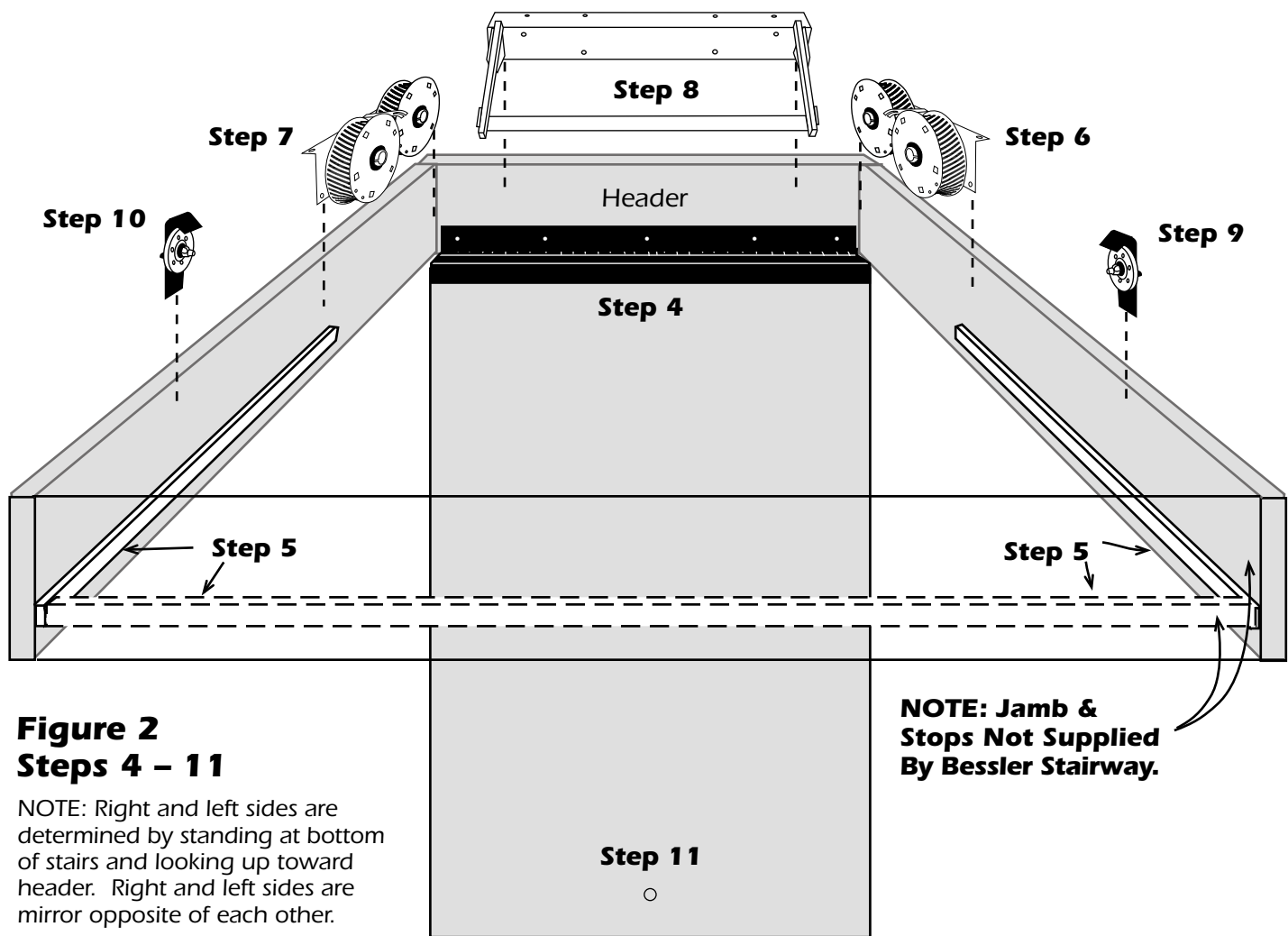

**Figure 2**  
**Steps 4 – 11**

NOTE: Right and left sides are determined by standing at bottom of stairs and looking up toward header. Right and left sides are mirror opposite of each other.

**NOTE: Jamb & Stops Not Supplied By Bessler Stairway.**

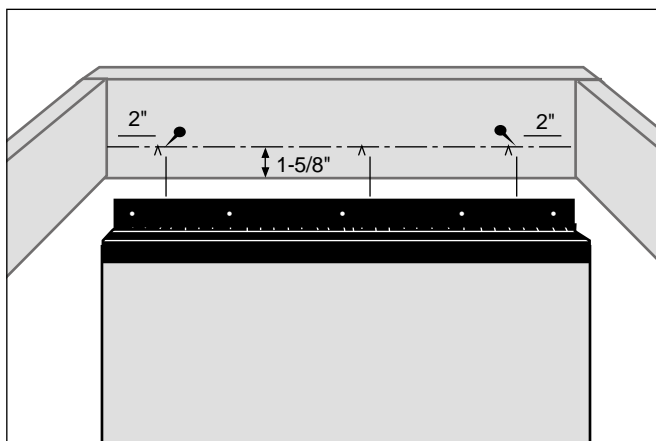

**Step 4**

On selected header, draw a line 1-5/8" up from the bottom of the door jamb. Then, approximately 2 inches from each corner, partially drive 2 small nails on this line for a guide. Hold Door Panel (#15) upright with the loose leaf of the offset piano hinge against the nails. Center the door panel in the finished jamb, predrill two holes and drive two 1" screws to hold the door. Now check the swing of the door to make sure it does not bind in the finished jamb. Make adjustments in the jamb as necessary. Install screws in the remaining three holes and remove 2 positioning nails. Make sure screw heads are screwed in flush.

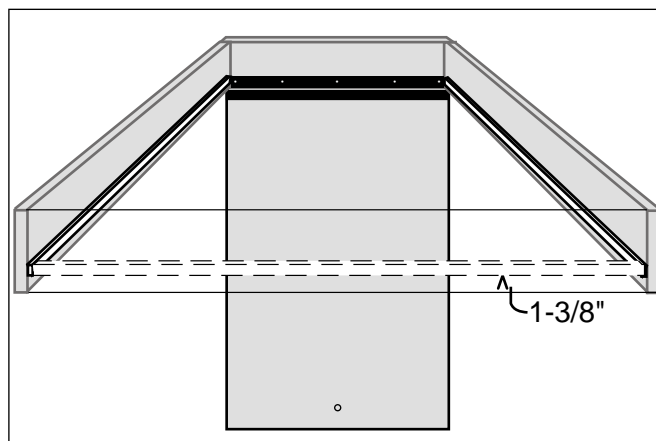

**Step 5**

Install 3/8" x 1-1/4" door stops (not supplied) on remaining three sides at 1-3/8" from bottom. Door stop may need to stop at Spring Drum Assemblies or be trimmed to allow placement of Spring Drum Assemblies in steps 6 and 7.

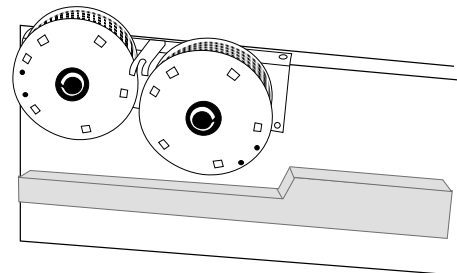

## Installing Hardware

The factory has sent two sizes of pan head screws. The 1" screws are to be used to attach metal to wood. The 1-1/4" screws are to be used to attach wood to wood. DO NOT USE 1-1/4" SCREWS AT THIS TIME.

Have on hand in attic: both Left and Right Spring Drum Assemblies (#6), two Pulleys (#9) and Header Guide Frame (#5).

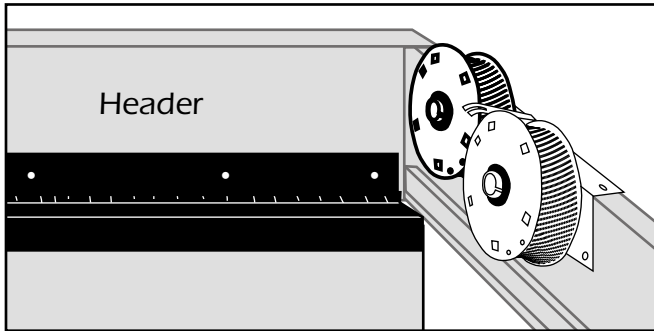

### Step 6

As you face the door, install Right Spring Drum Assembly (#6) in the corner against the selected header. There are seven holes in each Spring Drum Assembly. PREDRILL ALL HOLES USING A 1/8" DRILL BIT AND ATTACH WITH 1" SCREWS. LEAVE CABLES ALONE FOR NOW.

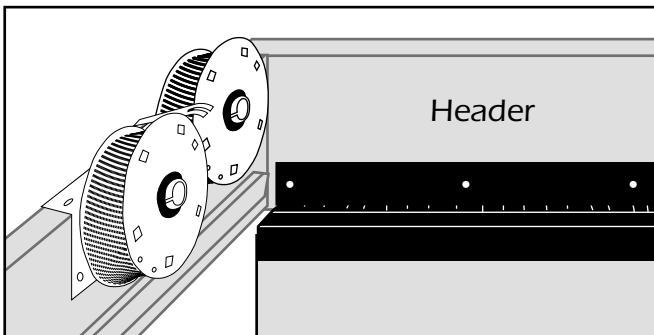

### Step 7

Install Left Spring Drum Assembly (#6) in the same manner as the Right Assembly.

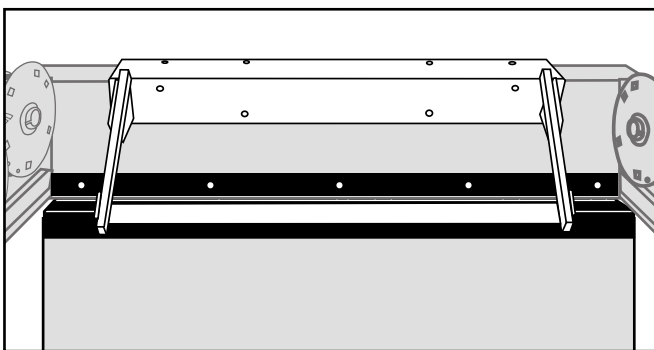

### Step 8

Install the Header Guide Frame (#5) on top of the jamb CENTERED between the Spring Drum Assemblies and SQUARED to the opening. There are approximately ten holes in the Guide Frame. PREDRILL ALL OF THESE HOLES AND ATTACH WITH 1" SCREWS.

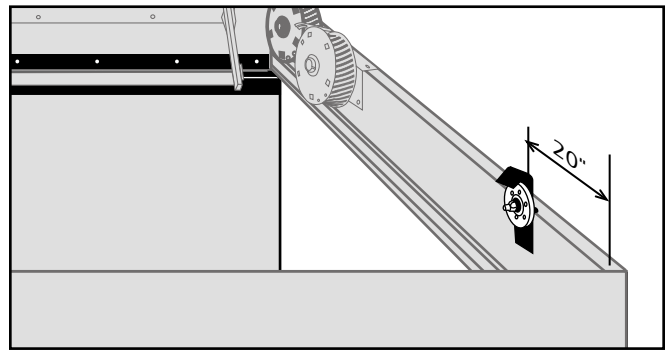

### Step 9

Mount the right side Small Pulley (#9) so that its centerline is 20" from the well end opposite the door and the tab is flush with the attic floor. PREDRILL THE THREE HOLES AND ATTACH WITH 1" SCREWS.

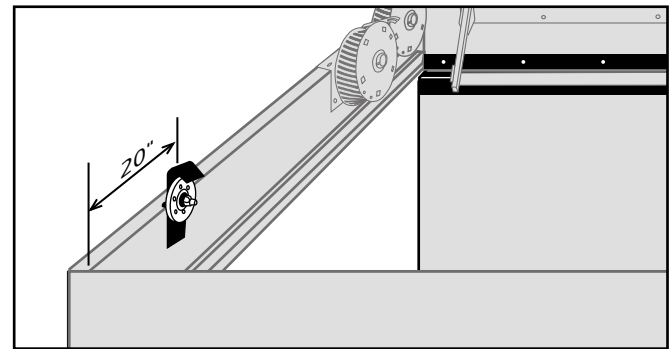

### Step 10

Mount the left side Small Pulley (#9) in the same manner as the right side.

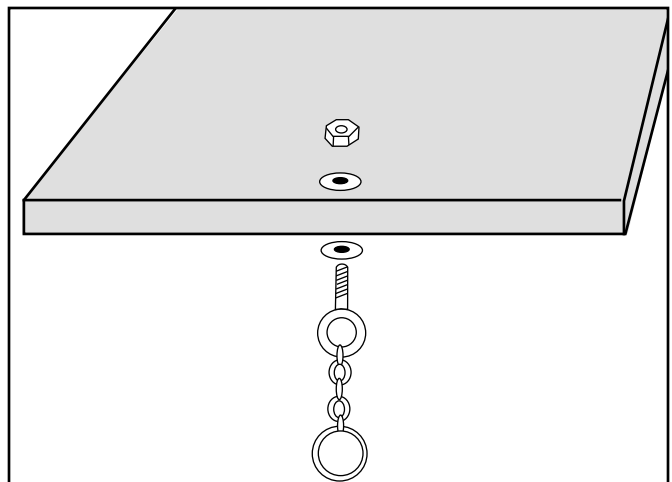

### Step 11

Install the Pull Chain (#17) in the door using the eyebolt, #10 x 24 nut, two ladder rod washers and chain. Spread the eyelet just enough to insert the round portion of the chain. Close up the eyelet, then insert eyebolt through 1 washer and door. Add a washer on the threaded end and tighten nut with 3/8" nut driver. You can wait to attach pull ring later when you adjust chain for length.

This may be a good place to double-check the swing of the door to insure that it doesn't bind against the finished jamb.

## Assemble Stringers and Treads:

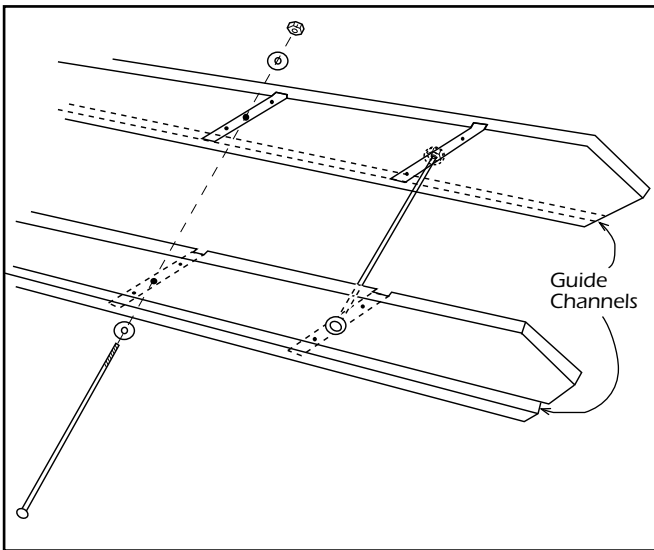

### Step 12

Lay out stringers on ground or saw horses with the guide channels on the bottom and facing outward. Align the middle holes at each gain, insert ladder rods through washers and drive through middle holes of both stringers. Place a washer on the threaded end and run a nut on each ladder rod until two full threads are showing past the nut.

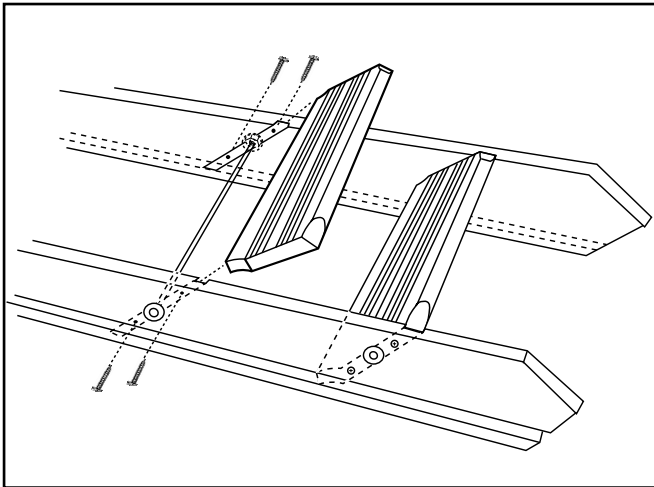

### Step 13

Spread the stringers apart. The treads are precision cut to act as spacers to hold the outside width of the stairs at a constant measurement and should fit snugly into the gains, groove side up. You may have to use a mallet to install the treads all the way into the gains. Start at the bottom of the stairs and **INSTALL ALL BUT THE TOP THREE TREADS**. **NOTE: THE TOP TREAD IS DEEPER THAN OTHERS.** As you install the treads, check the outside width of the stairs, both front and back, to maintain the correct measurement (See Table 3, Pg. 11).

At first, flush the beveled edge with the front of the stringer and make sure the treads are seated all the way into the gains. Then, if needed, try sliding the treads in or out, front to back, about 1/8" to achieve measurement. You are working with a pine wood product. As you know, pine can vary slightly, even when milled.

Attach treads to stringers with four 1-1/4" screws. For easy assembly, drill treads with a 1/8" bit through the holes in the stringers. Tighten ladder rod nuts and peen the threaded end of the rods to keep nut from coming off. The outside ladder width for Models 30 & 40, should be 17-1/16" ± 1/32" along the length of the stringers. The Model 70 should be 18-7/8" ± 1/32".

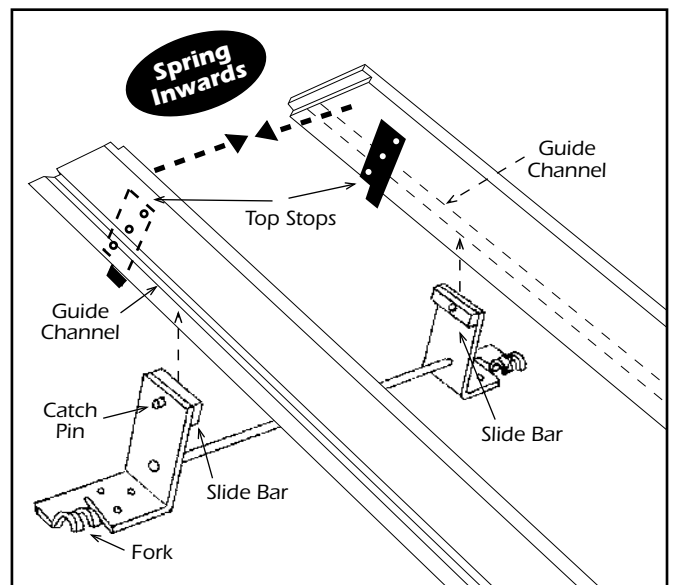

### Step 14

Before lifting the stair section, install the Door Guide Frame (#10). "Spring" in the top of the stringers where you left out the top three treads and insert the Door Guide Frame Slide Bars (#10a) into the guide channels on the outside of the stringers just below the riveted top stops. Be sure the FORKS POINT DOWN and the CATCH PIN is on the left side of the stringer. Slide the Door Guide Frame all the way to the bottom of the stairs. **DO NOT FORCE** as this may spread the bars or damage the brackets.

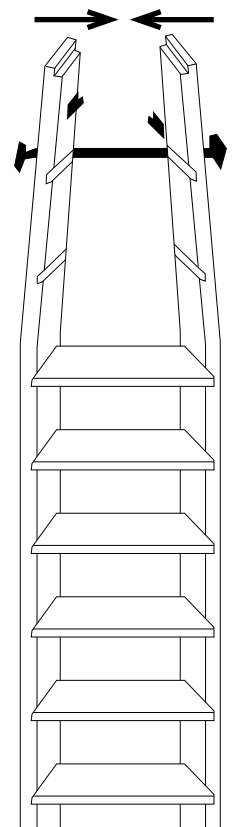

## Installing The Stair Section

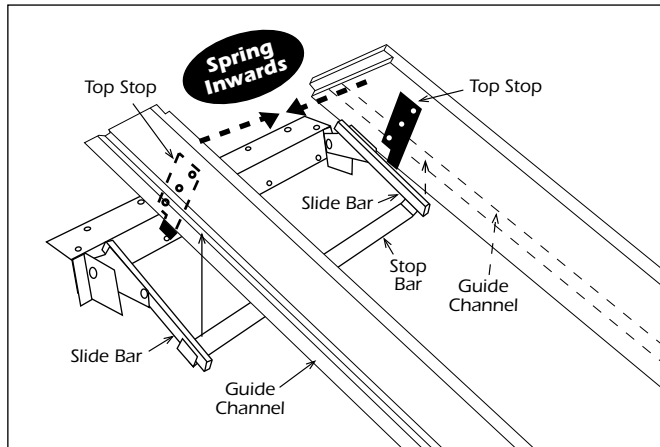

### Step 15

Lift the stairs up to the header. "Spring" in the top of the stairs and insert slide bars of Header Guide Frame (#5) into the guide channels on the outside of the stringers just below the riveted top stops. Make sure the slide bars are seated in the guide channels. (DO NOT FORCE the slide bars of either the Door Guide Frame or Header Guide Frame over the edge of the ladder as this may spread the bars or damage the brackets).

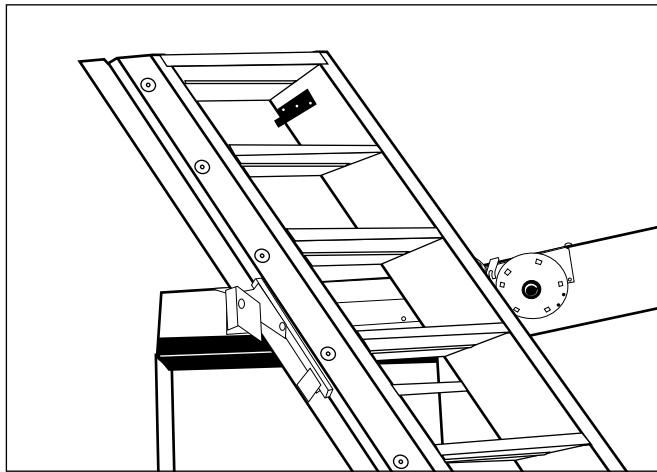

### Step 16

To install the top three treads, have helper push and hold the stairs up to where their position on the stringers clears the attic floor. Install the treads in the same manner as the other treads (Steps #12 & #13). The top tread is deeper, 7-1/4".

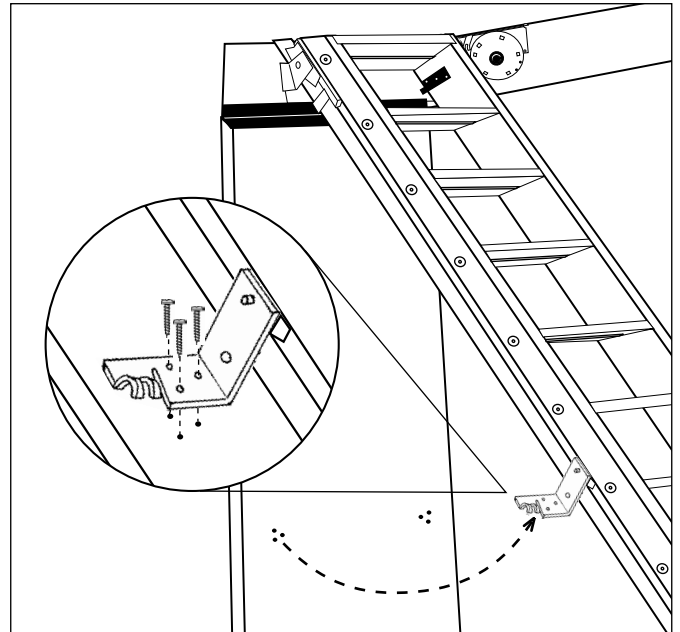

### Step 17

Lower the stairs until the top stops rest against the stop bar of the Header Guide Frame (#5) and the bottom of the stairs are on the floor. The top tread should be level with the attic floor. Swing the Door Panel (#15) to the stairs and slide the Door Guide Frame (#10) up on the stringer and align with the predrilled holes in the Door Panel. Secure with six 1-1/4" screws.

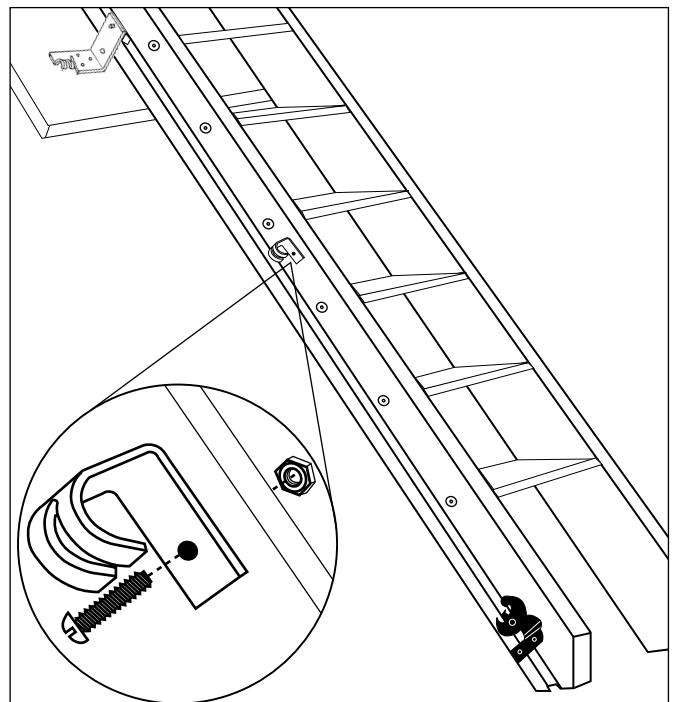

### Step 18

Fasten Cable Holders (#13) to both stringers where holes are predrilled near fourth tread from bottom. Use a 1/4" x 1-1/4" machine screw and lock nut.



## Stringing The Cables

On the Spring Drum Assembly, both cables are attached to a shipping fork. The drums are shipped with tension to keep cables secure. **DO NOT UNHOOK FROM SHIPPING FORK UNTIL READY TO STRING.**

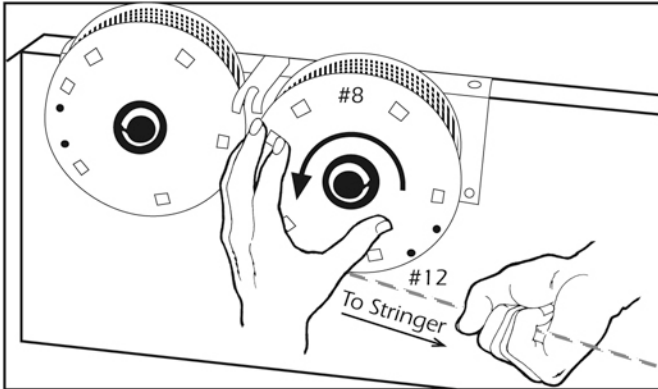

### Step 19

Start with the Stringer Drum (#8), the drum furthest from the corner. The cable will have approximately the correct amount of tension (3 turns). Carefully remove the Cable (#12) from the shipping fork while holding onto the drum. **WARNING: DO NOT LET CABLE SLIP FROM YOUR HAND SINCE SUDDEN RELEASE OF TENSION CAN BREAK OR BACK-WIND THE SPRING AND CABLE TRAVEL MAY CAUSE PERSONAL INJURY.**

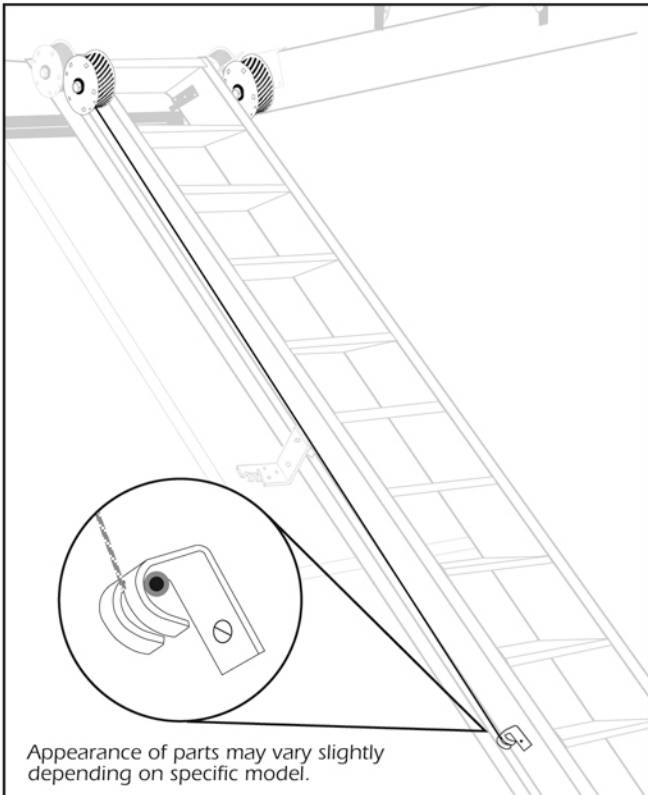

### Step 20

Keeping cable **ALIGNED** with drum, pull cable down and hook to cable holder (#13) on stringer. Repeat for left side. (Left side is mirror opposite of right side.) **NOTE:** Refer to Step 25 for final adjustment of tension.

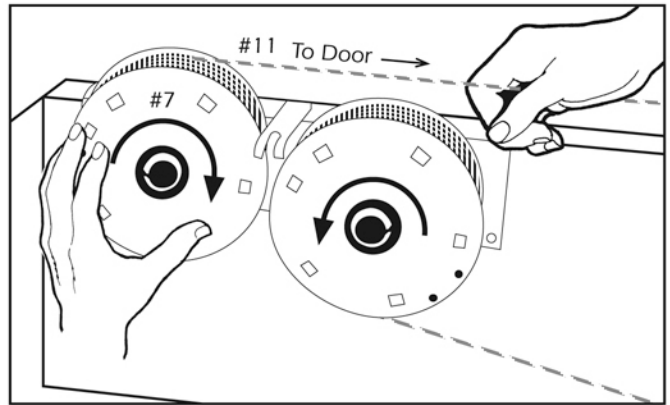

### Step 21

Connect the Door Cable (#11) by carefully removing the cable from the shipping fork. **CAUTION: Door cables come with tension for shipping purposes only. Back off tension on Door Drum slowly until all tension is released.**

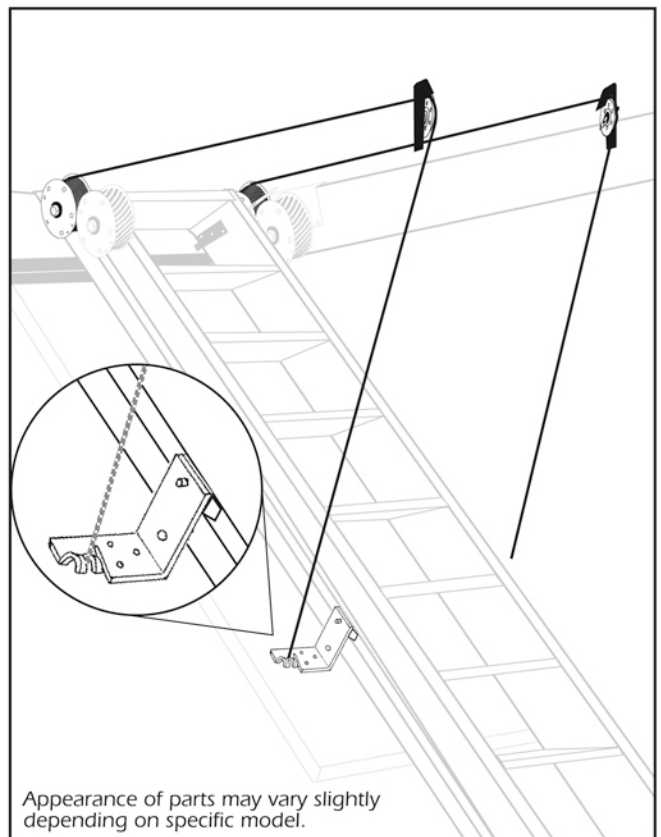

### Step 22

Starting with all the cable wrapped on the drum, pull the cable parallel to the attic floor and feed cable over Pulley (#9) and down to **FORK** on the Door Guide Frame (#10). Hook cable's Stop Button under the fork. Repeat for left side. (Left side is mirror opposite of right side.) **WARNING: DO NOT LET CABLE SLIP FROM YOUR HAND SINCE SUDDEN RELEASE OF TENSION CAN BREAK OR BACK-WIND THE SPRING AND CABLE TRAVEL MAY CAUSE PERSONAL INJURY. NOTE:** Refer to Step 25 for final adjustment of tension.

## Attach Handrail

### Step 23

Top post should be mounted plumb to inside of stringer and resting on second tread from the top using three 1-1/4" screws. Attach handrail about 4" past top post with two 1-1/4" screws. Go to the other end and attach bottom post to inside of stringer with post resting on bottom tread and plumb under the handrail, attach with two 1-1/4" screws. Position other posts at equal intervals on stairs. There are three posts for sizes 1 – 4 and four posts for sizes 5 – 7. Handrail may be attached to either side and further down the stairs, depending on Plumb Height and customer's wants. Make sure horns of posts are covered by the handrail. Always use handrail when walking up and down stairways. **HANDRAIL IS FOR BALANCE PURPOSES ONLY AND IS NOT LOAD BEARING.**

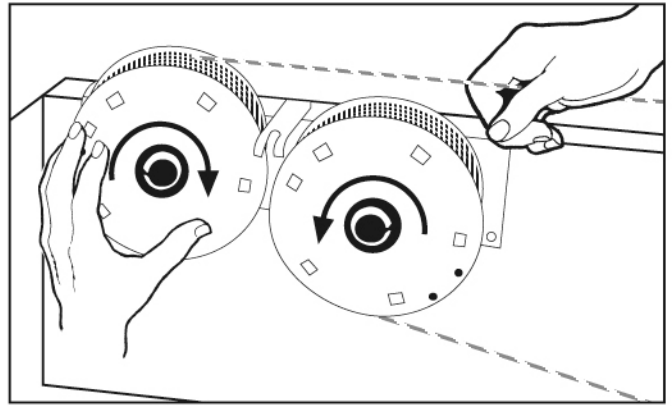
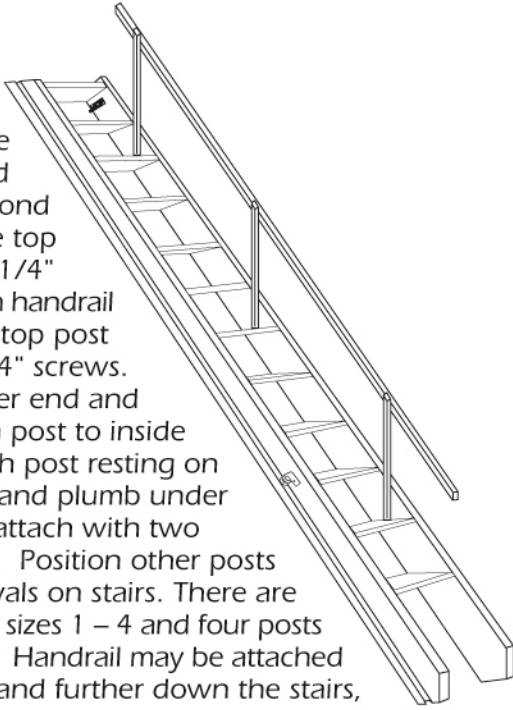

Right Hand Spring Drum Assembly illustrated. Left Hand Assembly is mirror opposite of right.

## Adjust Spring Tension

### Step 25

Always work toward using the minimum amount of tension to do the job. On the average, one complete turn of the drum will add or reduce approximately 2 lbs. of lift.

#### Stair Tension

Have enough tension for minimum force to slide the stairs up to the stored position, but not so much tension that the stairs creep up when resting on the floor. This could cause accidental tripping. Too little tension may allow stairs to slide too forcefully to floor or may cause stairs to feel heavy.

#### Door Panel Tension

Enough tension should be used to close the door very slowly without slamming, but enough to hold the door against the stops.

Add tension by adding more turns of cable. Take the end of the cable loose from the cable holder and slowly let it wrap up on the drum. While you still have a length of cable in your hand, hold the drum firmly and wrap additional cable around drum as needed. Return cable to cable holder. Repeat for other side.

Reduce tension by unwrapping additional cable. Take the end of the cable loose from the cable holder and slowly let it wrap up on the drum. Hold the drum firmly and unwrap additional cable from drum as needed. Return cable to cable holder. Repeat for other side.

**WARNING:** DO NOT LET CABLE SLIP FROM YOUR HAND SINCE SUDDEN RELEASE OF TENSION CAN BREAK OR BACK-WIND THE SPRING AND CABLE TRAVEL MAY CAUSE PERSONAL INJURY.

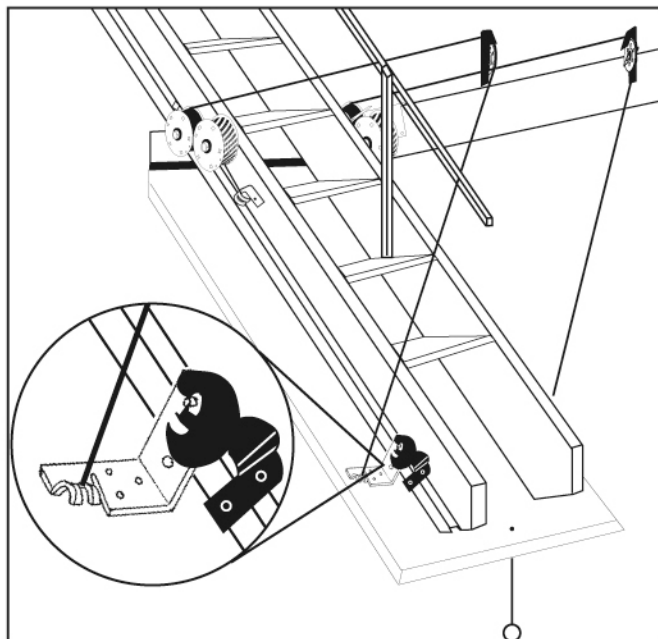

### Step 24

Raise the stairs to the stored but still open position on door panel. Make sure Catch Lock (#14) has engaged the Catch Pin by pulling the stairs back about 1/2". **DO NOT LET THE DOOR SLAM.** Slamming the door may cause damage to the Stringer Guide Channel or tear the Door Guide Frame (#10) from the door. **NOTE:** Refer to Step 25 for final adjustment of tension.

## Trouble Shooting

If stair section is jumping out of track:

- Check width of stairs.
- Check dimension between slide bars.  
You may adjust the slide bars by bending the bracket slightly in or out as needed. (see Table 3)

If stair section is hard to move or binding:

- Make sure slide bars are in the guide channel over the entire length of travel.
- Lubricate guide channel with grease or wax.
- Look for gouge marks and check width of stairs at that point. (see Table 3)
- Check seating of treads and tightness of ladder rods.

If cable runs off of drum when moving stair section:

- Check to see if stair is centered in opening.
- Check for proper alignment of hardware.
- Check for alignment and plumbness of jamb.  
Mounting brackets can be shimmed to correct minor misalignment.

If stair section comes down too fast:

- Add spring tension to stringer drum (#8). Refer to Step 25 to adjust tension.

If stair section "creeps up" from down position:

- Reduce spring tension to stringer drum (#8). Refer to Step 25 to adjust tension.

If Door Panel fails to close:

- Add spring tension to panel drum (#7). Refer to Step 25 to adjust tension.
- Make sure screw heads are seated against hinge.
- Check for foreign debris.

If Door Panel slams shut:

- Reduce spring tension to panel drum (#7). Refer to Step 25 to adjust tension.

If you break or back-wind a spring:

- CALL THE FACTORY.

**WARNING:** The spring inside the drum, even though broken or back-wound, is under EXTREME compression. DO NOT OPEN THE SPRING DRUM. Call the factory for instructions before returning to the address on back for repairs.

**TABLE 3**

| Model     | Slide Bar Inside Width | Ladder Outside Width |
|-----------|------------------------|----------------------|
| #30 & #40 | 16-5/8"                | 17-1/16" ± 1/32"     |
| #70       | 18-7/16"               | 18-7/8" ± 1/32"      |



3807 Lamar Ave. ■ Memphis, TN 38118  
901-360-1900 ■ Fax 901-795-1253  
[www.bessler.com](http://www.bessler.com) ■ E-Mail: [bessler@bessler.com](mailto:bessler@bessler.com)